



STRUCTURE-SPECIFIC SELECTION OF EARTHQUAKE STRONG GROUND MOTIONS FOR NONLINEAR ANALYSIS OF RC STRUCTURE

Z. Wang⁽¹⁾, Y. Xie⁽²⁾, T. Friis⁽³⁾, D. Ji⁽⁴⁾, X. Xiong⁽⁵⁾, W. Yuan⁽⁶⁾, A. Sextos⁽⁷⁾, E. Katsanos⁽⁸⁾

⁽¹⁾PhD Student, State Key Laboratory of Disaster Reduction in Civil Engineering, Tongji University, Shanghai, China, 1710199@tongji.edu.cn

⁽²⁾PhD Student, Department of Structural Engineering, Tongji University, Shanghai, China, xieyf@tongji.edu.cn

⁽³⁾PhD Student, Department of Civil Engineering, Technical University of Denmark, Kgs. Lyngby, Denmark, tofri@byg.dtu.dk

⁽⁴⁾Assistant Professor, School of Civil Engineering, Harbin Institute of Technology, Harbin, China, jiduofa@hit.edu.cn

⁽⁵⁾Professor, Department of Structural Engineering, Tongji University, Shanghai, China, xiong_xueyu@tongji.edu.cn

⁽⁶⁾Professor, State Key Laboratory of Disaster Reduction in Civil Engineering, Tongji University, Shanghai, China, yuan@tongji.edu.cn

⁽⁷⁾Professor, Department of Civil Engineering, School of Civil, Aerospace and Mechanical Engineering, University of Bristol, Bristol, UK, a.sextos@bristol.ac.uk

⁽⁸⁾Assistant Professor, Department of Civil Engineering, Technical University of Denmark, Kgs Lyngby, Denmark, vakat@byg.dtu.dk

Abstract

Response history analysis (RHA) constitutes nowadays the most prevailing method to undertake linear and nonlinear analysis of structural systems being subjected to the time-varying earthquake forces. Compared to the conventional analysis methods (i.e., modal response spectrum and equivalent static analysis respectively), the superiority of the RHA is mainly associated with the capacity to: (i) identify the hierarchy of the failure mechanisms, (ii) account for the energy dissipation and force redistribution mechanisms as well as, (iii) favor the control of both the structural and non-structural damage during the strong ground shaking. It is a time-domain structural analysis method and as such, demands the use of suite of earthquake motions that correspond to a predefined earthquake scenario. Intensive research effort has been lately spent on scrutinizing methods for selecting and scaling earthquake strong ground motions since it has been shown that the earthquake excitations and their inherent uncertainty can affect drastically the calculated response and lead, for example, to highly scattered structural analysis results. The latter undermines, though, the reliability of the structural demand parameters, which is of high relevance mainly for design and design verification purposes. Along these lines, a structure-specific method for selecting and scaling earthquake records has been recently introduced accounting explicitly, among other factors, for the dynamic properties of the structure under study and prioritizing sets of motions that disfavor the structural response variability. This method, being developed under the ISSARS computational framework, has been successfully tested in terms of linear RHA results. To further extend the validation and hence, the applicability of the proposed method, its performance is evaluated via the current study in terms of nonlinear analysis. Especially, a rc multistory, frame-resisting structure is modelled by using OpenSees while multiple nonlinear RHA are undertaken by the use of earthquake motions, the latter being appropriately selected, formed into suites and prioritized for structural analysis purposes via the use of the structure-specific earthquake records selection method. The code-based, conventional method to select and form sets of earthquake motions is also applied and the intra-suite variability of the corresponding response results is compared with the one induced by the structure-specific earthquake records selection method. The latter is expected to lead to response parameters with lower variability and hence, design values of increased reliability.

Keywords: nonlinear response history analysis, structure-specific earthquake records selection, response variability

1. Introduction

Response history analysis (RHA) has been nowadays emerged as the prevailing method for linear and/or nonlinear analysis of structures independently of their size, geometry, complexity and importance. Contrarily to the more conventional structural analysis methods (i.e., the equivalent static analysis and the modal response spectrum analysis), the RHA is a rigorous method used for the seismic design of new structures and/or the assessment of existing ones accounting for the energy dissipation through the hysteretic response, the force-redistribution mechanisms as well as the hierarchy of the failure mechanisms. The level of the earthquake-induced structural and non-structural damage can be also captured by performing the nonlinear



RHA, the latter being a time-domain structural analysis method that requires as input the use of a single or multiple suites of earthquake strong ground motions. However, research work has found that among various uncertainty sources, being related to structural and soil material properties, modelling approximations, analysis and design approximations as well as the seismic motions, the latter exerts the strongest influence on structural response [1]. Thus, the selected earthquake-induced ground motions may affect the reliability of the seismic design or assessment outcome. Over the last 25 years, intensive research has been dedicated to address the challenging problem of selecting and scaling earthquake motions to be used for the RHA of structures [2, 3]. Depending on the scope of such a time domain analysis, i.e., the code-based design verification of structures or the assessment of the seismic performance of existing structures, either the central (average) estimate of the response or its full probability distribution has to be pursued. Especially, the rationale of estimating the central tendency of an engineering demand parameter, EDP, is related to the code-prescribed design and/or design verification of structures, in which stable estimates of the average response need to be reached in order to secure the reliability of the design outcome [4-6]. Thus, it is highly relevant that the methods, being used to select and scale seismic motions, handle efficiently this critical consideration (i.e., stable average response demands). Otherwise, the reliability of the design process may be undermined.

The selection of earthquake strong ground motions has to be consistent with a predefined earthquake scenario. Among several seismological, strong ground motion and site-related parameters that have been already employed to select earthquake records for RHA of structures (e.g., [7, 8]), the majority of the relevant state-of-the-art methods designate the earthquake magnitude and the source-to-site distance as the primary criteria for the preliminary selection of seismic motions. The compatibility of the selected earthquake motions with a predefined target spectrum needs, then, to be quantified and the most compatible records are usually prioritized for the RHA of the structures of interest. To this end, various target spectra have been proposed yet, founded on the basis of different assumptions and being conditional not only on seismotectonic conditions but also on strong ground motion parameters and structural properties [9-11]. Independently, though, on the definition of the target spectrum, research advancements have been used to modify the recorded seismic motions in order, eventually, to achieve matching with the target spectrum. Amplitude-based scaling has been employed and the scaled seismic motions can satisfy the spectral compatibility requirements by preserving the inherent variability of the seismic excitations, their frequency content and the spectral shape (e.g., [12]). Alternatively, various techniques have been defined to modify the frequency content of the recorded motions and thus, fulfill the matching criteria with the target spectrum (e.g., [13]). However, the generation and, eventually, use of such artificial motions for RHA of structures has been found to lead to unconservative bias in the estimation of the average structural response [12, 14].

Despite the substantial progress made already for the selection and scaling of seismic motions, the current state-of-the-practice reflects insufficiently and simplistically the main findings of those advanced methods. Thus, the engineers need often to take subjective decisions that may result in structural solutions of limited reliability and confidence. For example, the performance of nonlinear RHA of a multistory building by using fully legitimate Eurocode 8-compatible motions suites led to highly scattered response results that, in turn, degraded the reliability of the structural analysis outcome [15]. Such an increased variability in the seismic demand is confirmed by additional studies [16, 17] highlighting the deficiencies that the engineers and researchers are exposed to when the code prescriptions should be applied. To counteract this problem, advanced methods supported by algorithms, have been introduced to facilitate selecting and scaling of seismic motions (e.g. [18, 19]). The application of those methods in design-office environment is, though, doubtful unless hazard disaggregation data is available. Moreover, the critical objective of the reduced seismic demand variability is often disregarded jeopardizing, in such a way, the reliability of the design results.

Along these lines, a decision support process has been recently introduced to facilitate the selection and scaling of earthquake ground motions and provide prequalified suites of seismic records that lead, most likely, to stable and thus, reliable design (average) demand values [20]. Such a process, being already embedded into the earthquake records selection and scaling computational system ISSARS [21], can be primarily used for the code-conformed design and/or design verification of structures, in which the stability



of the central response estimates is pursued. The earthquake records, being initially selected considering seismological and strong ground motion parameters, are formed into numerous suites of records that are, then, ranked by a complex system considering: (a) the spectral variability among the selected motions of each suite and, (b) the convergence between the suites average spectrum and the target one. The dynamic properties of the structure studied including the elastic periods and the earthquake-induced inelastic ones as well as the modal mass participation factors are also considered within the current framework so as a structure-specific process for earthquake records selection and scaling is achieved. The performance of ISSARS and the associated structure-specific selection and scaling of earthquake records has been validated by considering linear RHA of a multistory reinforced concrete (rc) building, for which the stability of the average (design) estimates was highly favored in comparison with the conventional, code-like approach for selecting and scaling seismic records. On the other hand, the performance of the specific process has not yet shown in case of response results obtained via nonlinear RHA of structures. Therefore, a multistory, rc frame building was modelled herein and a nonlinear RHA scheme was conducted by using motions suites that were formed and ranked according to the conventional, code-like approach and the structure-specific one. The performance of the two methods was evaluated in terms of the induced variability of the response results that, in turn, reflects the stability and hence, reliability of the average seismic demand estimates.

2. Structural Model

A 10-story rc building, expected to host offices, was considered as the testbed structure to facilitate the assessment of the structure-specific selection and scaling of earthquake motions. The building consists of five and three bays along the x-x and y-y direction respectively. Moment resisting frames are used to withstand the lateral load imposed by the earthquake actions. The total building height is 30.6 m with a first story being of 3.6 m high while the upper stories are of 3.0 m high. Both the plan and elevation views of the ten-story building are shown in Fig. 1. The rc frame building, assumed to be located in Shanghai, was designed according to the Chinese Code for the Seismic Design of Buildings (GB50011-2010) [22] by using a commercial design software that complies with the current regulatory framework of the Chinese codes. The design PGA was taken equal to 0.1 g, which is prescribed by the Seismic Ground Motion Parameters Zonation Map of China (GB18306-2015) [23] to design a building by using the response spectrum analysis method and considering the Shanghai area that belongs to 7th degree seismic intensity zone. Moreover, the site class was considered to be of Class II, which corresponds to a rock or stiff soil site with an equivalent shear wave velocity from 250 to 500 m/s [22]. The characteristic period, T_g , being also essential for the building design, was considered equal to 0.35 corresponding to the first group of the classification of design earthquake and the chosen site class. The earthquake actions were combined with gravity loads, the latter being described by the following combination $G + 0.5Q$, where G represents the dead load including exterior walls, interior partitions and additional dead loads (e.g., floor finishes) while Q is the live load. The dead load was considered equal to 4.8 kN/m² and 5.0 kN/m² for the non-roof and roof floor respectively. Moreover, live load of 2.0 kN/m² was accounted for all the floors. Regarding the materials used herein, concrete of class C30, as specified by the Code for Design of Concrete Structures (GB 50010-2010) [24], was employed for the concrete elements while the HRB400 steel with characteristic yield strength, f_{yk} , equal to 400 MPa was adopted for the longitudinal and transverse reinforcing bars. It is notable that characteristic compressive strength, $f_{ck,cube}$, of 30 MPa, defined for the standard cube specimen with the size of 150 × 150 × 150 mm, is associated with the concrete class C30 while its characteristic compressive strength, f_{ck} , defined as the compressive strength of the standard specimen with size of 150 × 150 × 300 mm in prism shape, is equal to 20.1 MPa [25]. However, the design values used herein for the compressive strength of C30 concrete and the yield strength of HRB400 bars are specified to be equal to 14.3 MPa and 360 MPa respectively [24]. Regarding the design of the structural elements, the slab at each story is of 120 mm thick. Along the transverse (y-y) direction of the building, the cross section of the beams for the long and short bays are 250 × 500 mm and 250 × 400 mm. Moreover, the cross section of the beams is 250 × 500 mm along the longitudinal (x-x) direction. Regarding the columns, their cross section is 650 × 650 mm for the first five floors and 550 × 550 mm for the rest of the floors. Figure 2 shows cross-sections and reinforcement details



for indicative structural elements that belong to the external frame along the longitudinal direction of building. Longer description of the building design is not provided due to page limitation.

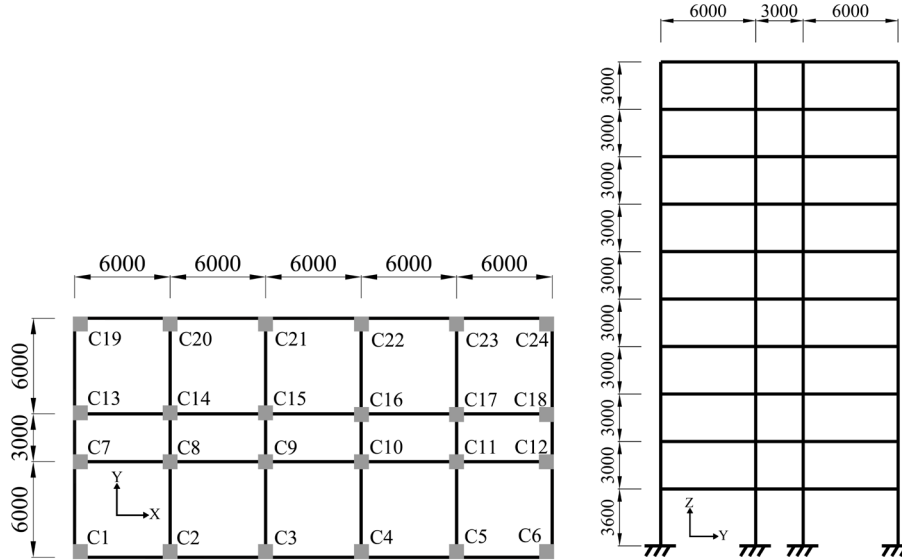

Fig. 1 – Plan view (left) and elevation view (right) of the ten-story rc building adopted for the current study.

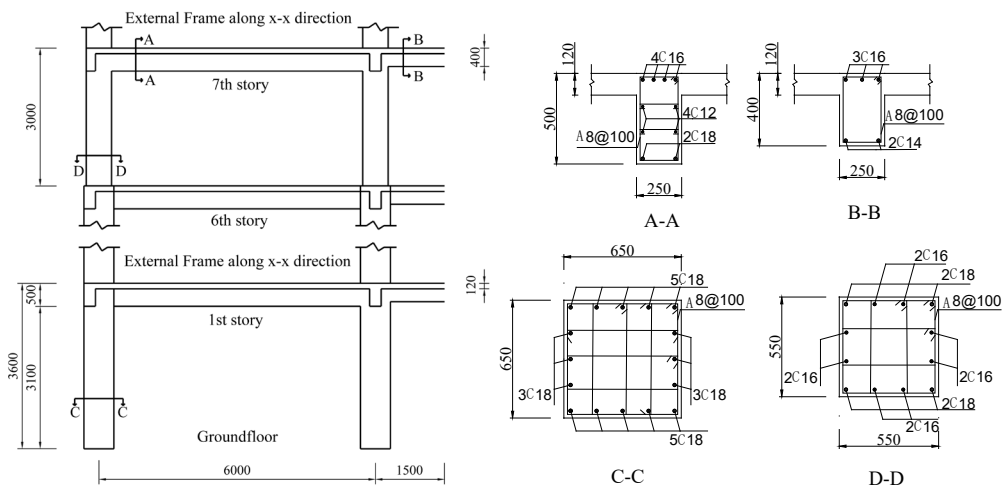

Fig. – 2 Detailing information for indicative cross sections of the testbed building adopted herein.

A 3D finite element model developed using the OpenSees finite element code was adopted to perform the RHA of the multistory building, being already designed according to the Chinese regulatory framework. In order to account for the nonlinear behavior of the structure, both material and geometric nonlinearity (i.e., P-delta effect) were considered. The columns and beams were modelled using fiber-type displacement-based beam-column element. For the fiber-section models, the one-dimensional stress-strain behavior of concrete and reinforcing steel were simulated using the *Concrete01* and *Steel01* material models. The *Concrete01* material law reflects a uniaxial Kent-Scott-Park concrete material with degraded linear unloading/reloading stiffness according to the work of Karsan-Jirsa and with no tensile strength. The *Steel01* material law is a uniaxial bilinear steel material accounting for kinematic hardening. The compression strength of the unconfined concrete was taken equal to the characteristic value, i.e., $f_{ck} = 20.1$ MPa, and $0.2f_{ck}$ was the value considered for the ultimate strength. The corresponding strains were 0.002 and 0.004. Meanwhile, the elastic modulus, E_s , of the steel and its post-yield stiffness were considered equal to 200 GPa and $0.02E_s$. Rayleigh



damping was employed for the RHA. The eigenvalue analysis of the structural model enabled the calculation of its dynamic properties, being essential for the structure-specific selection and scaling of seismic motions. Table 1 lists the natural periods and mass participation ratios that correspond to the first five vibration modes

Table 1 – Dynamic properties of the structural system considered herein

Mode	Period T (s)	Modal mass participation ratio					Cumulative modal mass participation ratio	
		Γ_{ux}	Γ_{uy}	Γ_{Rx}	Γ_{Ry}	Γ_{Rz}	$\sum \Gamma_{ux}$	$\sum \Gamma_{uy}$
1	1.674	0.000	0.754	0.996	0.000	0.000	0.000	0.754
2	1.659	0.760	0.000	0.000	0.995	0.000	0.760	0.754
3	1.600	0.000	0.000	0.000	0.000	0.785	0.760	0.754
4	0.537	0.000	0.104	0.079	0.000	0.000	0.760	0.858
5	0.534	0.103	0.000	0.000	0.122	0.000	0.863	0.858

Γ_{ux} and Γ_{uy} represent the mass participation ratios for modes corresponding to the translational degrees of freedom along the x-x and y-y horizontal directions of the structure. Γ_{Rx} , Γ_{Ry} and Γ_{Rz} represent the mass participation ratios for modes corresponding to the rotational degrees of freedom around the x-x and y-y directions and the vertical one (z-z).

3. Selection, scaling and ranking of suites of earthquake strong ground motions

The selection and scaling of the earthquake strong ground motions, being the essential input to perform nonlinear RHA of the multistory building studied herein, was accommodated by the use of the computational framework ISSARS [20, 21]. Especially, the definition of seismic scenario is required as the first step of the seismic records selection procedure. Thus, the PEER-NGA Strong Ground Motion Database was searched for strong ground motions that satisfy the following criteria: i) $5.5 < \text{earthquake magnitude } (M_w) < 8.0$, ii) $25 \text{ km} < \text{epicentral distance } (R) < 100 \text{ km}$, and iii) Site class D¹. Moreover, the earthquake motions selection strategy accounted for records being related to peak ground acceleration (PGA) between 0.1 g and 2.0 g. Hence, 111 pairs of horizontal components of seismic records were found to fulfill the aforementioned criteria, reflecting the seismotectonic environment of the Shanghai area, where the building was assumed to be designed [27]. However, a fraction of the criteria-legitimate records was, eventually, used to form all the possible suites of records and perform RHA of the structure studied herein. Indeed, 20 pairs of horizontal components of earthquake records were selected (Table 1) that led ISSARS to form 77,520 different suites consisting of seven pairs of seismic motions. Those suites were then scaled to match the target spectrum, $S_{a_{target}}$, the latter chosen to be the reference spectrum for the rare earthquake event and the Shanghai area, which belongs to the 7th degree seismic intensity zone based on the Chinese Seismic Code [22]. Along these lines, the maximum horizontal earthquake influence coefficient, a_{max} , is prescribed to be equal to 0.5, which leads to PGA of 0.225 g for the target spectrum. However, the a_{max} was eventually doubled ($a_{max}=1.0$) in order to secure that the earthquake motions, matched with the 100% increased target spectrum, will lead the rc building to perform in the nonlinear regime. As defined above, the characteristic period, T_g , was considered equal to 0.35 while the 5% damping ratio led to 0.9, 0.02 and 1.0 for the γ , η_1 and η_2 parameters.

Spectral convergence was pursued between the response spectra of the seismic motions included in each suite and the target spectrum. Inspired by the current trends for spectral matching as prescribed by the seismic codes (e.g., the American Standards and the Eurocodes), a period range spanning from $0.2T_1$ up to $1.5T_1$, where T_1 is the fundamental period of a structure, was determined and the average elastic response spectrum, $S_{a_{avg}}$, calculated per suite of seismic records, was scaled (amplitude-wise) so as no ordinate of the average spectrum is lower than the corresponding one of the target spectrum within this period range. By doing so, a unique scaling factor, sf , was calculated by ISSARS and associated with each suite of motions.

¹The NEHRP site classification [26] is used by the PEER-NGA Strong Ground Motion Database to categorize the soil profiles, where the seismic motions have been recorded. This site classification uses the average shear wave velocity, $v_{s,30}$, of the upper 30 m of the soil profile: A (Hard rock) – $v_{s,30} > 1500 \text{ m/s}$, B (Rock) – $760 < v_{s,30} < 1500 \text{ m/s}$, C (Soft rock/very dense soil) – $360 < v_{s,30} < 760 \text{ m/s}$, D (Stiff soil) – $180 < v_{s,30} < 360 \text{ m/s}$ and E (Soft soil) – $v_{s,30} < 180 \text{ m/s}$.



The calculation of the scaling factors was followed by the prioritization of the formed suites of earthquake motions that, eventually, supports the decision-making about the choice of seismic records for RHA purposes. Two ranking systems were used in the current study. The first one is quantified by the use of a conventional and widely used spectral compatibility measure, δ_{conv} , that evaluates the convergence between the target spectrum and the average spectrum of motions suite within a specific periods range of [28, 29]:

$$\delta_{conv} = \sqrt{\frac{1}{N} \cdot \sum_{i=1}^N \left(\frac{sf \cdot Sa_{avg}(T_i) - Sa_{target}(T_i)}{Sa_{target}(T_i)} \right)^2} \quad (1)$$

where T_i is the sample structural period and N is the size of the sample within which the prescribed period range is discretized. Despite its rather straightforward application, the δ_{conv} ranking index does not guarantee stable enough average of the demand parameters, the latter being already detected for δ_{conv} -ranked suites of motions that were used for linear RHA of multistory rc building [20]. Therefore, an additional ranking system, quantified by the δ_{sv-sc} index [20], was also used herein accounting for two criteria: i) the intra-suite variability of motions (i.e. variability among the spectral ordinates of a motions suite and, ii) the quality of the compatibility between target and ground motions average spectrum. It is a structure-specific ranking system and both the aforementioned criteria are considered within a period range that:

- the upper bound, $T_{i,in}$, is defined by the earthquake-induced elongation of the first-mode period, quantified as a function of the elastic first-mode period, T_1 , of the structure and the force reduction factor, R_y (or behavior factor, q , in Eurocodes framework), for which the structure has been designed, and;
- the lower bound, $T_{n,80}$, is quantified by the vibration period of the n -th mode, for which the cumulative modal mass participation ratios are higher than 80% for both main horizontal directions.

Table 2 – Earthquake events and the associated strong ground motions used in the study

No.	Earthquake event (Date)	Earthquake Magnitude Mw	Recording station	Epicentral distance R (km)	Soil type	PGA (g)
1	San Fernando (09.02.1971)	6.61	LA - Hollywood Stor FF	39.49	D	0.164
2	Imperial Valley (15.10.1979)	6.53	El Centro Array #4	27.13	D	0.292
3	Taiwan SMART1 (14.11.1986)	7.30	SMART1 M07	75.25	D	0.106
4	Superstition Hills (24.11.1987)	6.54	El Centro Imp. Co. Cent	35.83	D	0.128
5	Spitak (07.12.1988)	6.77	Gukasian	36.19	D	0.120
6	Loma Prieta (18.10.1989)	6.93	Gilroy Array #3	31.4	D	0.342
7	Landers (28.06.1992)	7.28	Coolwater	82.12	D	0.177
8	Northridge (17.01.1994)	6.69	Canyon Country	26.49	D	0.303
9	Northridge (17.01.1994)	6.69	Pardee - SCE	25.65	D	0.385
10	Kobe (16.01.1995)	6.90	Amagasaki	38.79	D	0.342
11	Kobe (16.01.1995)	6.90	Takarazuka	38.6	D	0.427
12	Kocaeli (17.08.1999)	7.51	Duzce	98.22	D	0.206
13	Chi-Chi (20.09.1999)	7.62	TCU065	26.67	D	0.263
14	Duzce (12.11.1999)	7.14	Bolu	41.27	D	0.200
15	Denali (03.11.2002)	7.90	TAPS Pump Stat #10	84.42	D	0.238
16	Tottori (06.10.2000)	6.61	TTRH04	33.18	D	0.222
17	Iwate (13.06.2008)	6.90	Iwadeyama	42.02	D	0.230
18	El Mayor-Cucapah (04.04.2010)	7.20	RIITO	32.44	D	0.670
19	El Mayor-Cucapah (04.04.2010)	7.20	El Centro Differ. Array	60.65	D	0.310
20	Darfield (03.09.2010)	7.00	Riccanton High School	42.46	C/D	0.308

Within the framework of the δ_{sv-sc} -based ranking of the motions, an array of weighting factors, w_i , is also used to credit both the intra-suite variability of motions and the spectral convergence between the target



and the ground motions average spectrum in specific period zones according to their relevance to the dynamic response of the structure. For example, the spectral convergence within the first-mode related period zone, i.e., $[T_1, T_{l,in}]$, is weighted higher compared to the period zone that is associated with a higher mode (for example the fourth one). Such a weighting array is quantified by the following formula:

$$w_i = \sqrt{(\Gamma_{i,x})^2 + (\Gamma_{i,y})^2 + (\Gamma_{i,Rz})^2} \quad (2)$$

Accounting for the specific structural system and its dynamic properties (Table 1), the upper bound of the period range, being essential for the employment of the δ_{sv-sc} -based ranking system, was calculated equal to $T_{l,in} = 2.240$ s, while the lower bound is defined by the elastic vibration period of the fifth mode, $T_{5,80} = 0.534$ s. Additionally, the weighting factors, being assigned to the five mode-related period zones, were calculated equal to $w=[0.75, 0.76, 0.78, 0.10, 0.10]$. More details about the rationale and methodology for the definition of the δ_{sv-sc} index can be found in Ref. [20]. It is, though, noted that the ranking systems used herein, i.e., δ_{com} and δ_{sv-sc} , do not affect the spectral compatibility criteria and, in general, the selection and scaling procedure that one follows when, for example, a code-based approach has to be fulfilled. In other words, the ranking of the suites is independent on the way that the seismic records are selected, scaled and grouped into suites.

4. Response history analysis results

As already described, the primary objective of the study is to assess the performance and efficiency of the structure-specific selection and scaling of earthquake records, introduced in Ref. [20], in terms of prioritizing code-compatible suites of seismic records that induce, via nonlinear RHA, stable enough, and hence reliable, design values. Along these lines, both the conventional rating index, δ_{com} , and the refined one, δ_{sv-sc} , were employed to rank 77,520 different suites, being formed by the use of ISSARS and following the seismic scenario described above. Ten suites of motions, including the 1st, 3rd, 5th, 7th, 9th, 11th, 13th, 15th, 17th and 19th from each ranking scheme, were used to conduct nonlinear RHA of the 10-story building and the intra-suite variability for different EDPs, (i.e., top displacement, inter-story drifts, bending moments at the base of ground-floor columns) was assessed via the coefficient of variation, COV (i.e., $COV = \sigma/\mu$, where σ and μ are the standard deviation and arithmetic mean of a sample of values). To summarize, 140 bi-directional nonlinear RHA were performed (i.e., one case study building, two rating indices, 10 motions suites per rating system, seven pairs of seismic motions per suite). As mentioned in §3, the deliberate increase in the target spectrum considered herein (i.e., the target spectrum was considered twice as high as the one being prescribed for the area of Shanghai [35]) led the structural model to perform primarily in the nonlinear regime. The latter can be seen by the moment-curvature curves (Fig. 3), calculated at the base of C1 ground-floor column under the Darfield (Riccarton High School) and Iwate (Iwadeyama) strong ground motions.

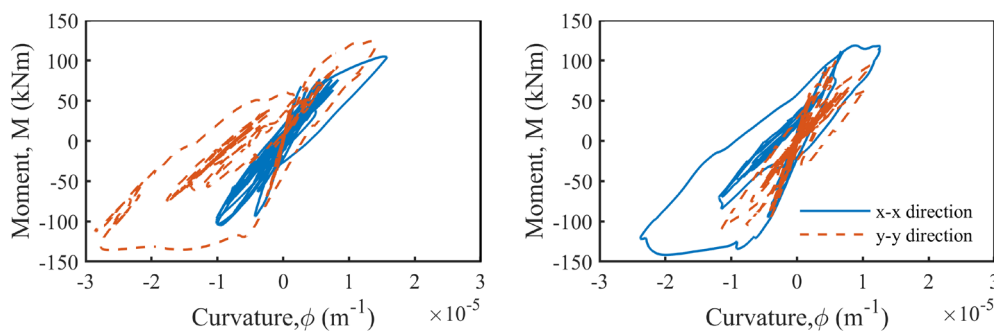

Fig. 3 – Nonlinear response at the base of two ground-floor columns under the seismic excitation of Darfield (Riccarton High School) (left) and Iwate (Iwadeyama) (right) strong ground motions.

Figure 4 shows the variability (COV values) for the chosen top displacement (along x-x and y-y direction) and the interstory drifts at 1st and 6th story respectively, which were calculated via nonlinear RHA



of the reference building when subjected to the 10 suites, ranked according to both the δ_{conv} and δ_{sv-sc} indices. Irrespectively of the EDP investigated, the average variability of the response, being associated with the 10 δ_{sv-sc} -ranked suites, is constantly lower compared to the average response variability induced by the 10 suites ranked with the use of the conventional index. Considering the entire set of the displacement-based EDPs employed herein, the average COV due to the δ_{sv-sc} -ranked suites was found to be equal to 0.466 while, on the other hand, average COV value of 0.613 was derived when the 10 δ_{conv} -ranked suites of motions were used for the RHA of the reference structural model. In other words, the δ_{sv-sc} -induced decrease in the response variability was found to be equal to 26% and 22% for the displacement-based EDPs along the x-x and y-y direction of the structure. Similar average trend can be seen when the force-based EDPs, chosen herein to be the bending moments, M_x and M_y , at the base of the C1 ground-floor column, were used to assess the efficiency of the δ_{sv-sc} -based ranking system for suites of motions (Fig. 5). Particularly, the use of the 10 δ_{conv} -ranked suites of motions led to average COV of 0.234 while 24% less, on average, was the variability of the moment-related response results by using the 10 suites of motions that were ranked by the δ_{sv-sc} index. The superiority of the δ_{sv-sc} -based ranking of suites to result in nonlinear response estimates with reduced variability is also stressed by the boxplot of Fig. 6, in which the COV of the relevant statistical values (i.e., minimum, first quartile, median, third quartile and maximum value respectively) corresponding to the 10 δ_{sv-sc} -ranked suites is considerably lower than the variability induced by the following the conventional, code-like approach for ranking the suites of motions.

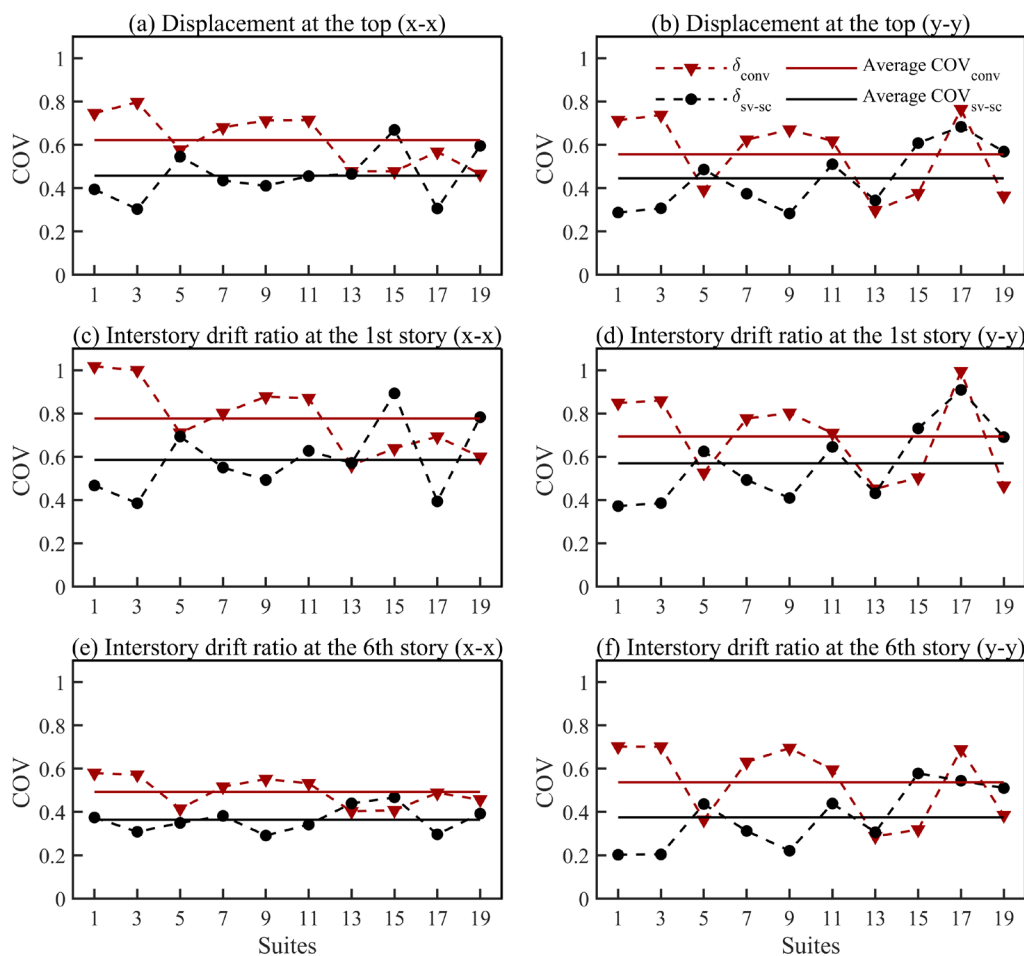

Fig. 4 – Intra-suite variability of displacement-based EDPs derived from nonlinear RHA with the use of 10 motions suites ranked according to the δ_{sv-sc} and δ_{conv} respectively.

Accounting for the 140 nonlinear RHA, almost 75% of the ten δ_{sv-sc} -ranked motions suites led to less scattered displacement-based response estimates compared to the ones that were derived by the use of the



δ_{conv} -ranked suites of motions. The rest 25% of those ten δ_{sv-sc} -ranked suites were found to underperform in terms of their efficiency to induce response results with lower variability. In case of the force-based response results investigated herein, the success rate of the δ_{sv-sc} -ranked motions suites was found, on average, slightly lower, i.e., 70%. For example, when the interstory drift (along the x-x direction) at the 1st story is of interest, the 15th suite of motions, ranked by the δ_{sv-sc} index, underperforms by approximately 39.8% compared to the 15th motions suite, being conventionally ranked. A closer insight of the two suites enables to detect that they have five (out of seven) pairs of strong ground motions in common (No.1, No. 3, No. 17, No. 19 and No. 20) while, there is 18% difference between the two scaling factors calculated by ISSARS for the two suites, i.e., $sf_{sv-sc}=1.48$ and $sf_{conv}=1.74$. However, the variability (COV) that the aforementioned five common pairs of strong ground motions induced to the interstory drift of the first story was found to be equal 0.449 for the 15th δ_{sv-sc} -ranked suite and 0.347 for the 15th δ_{conv} -ranked suite. Such a difference ($0.449/0.347=130\%$) would not be expected for structural responses derived by performing linear RHA scheme, for which this variability ratio would be equal to unity. The latter can be seen as an indication that when nonlinear RHA results are of interest, the scaling factors, calculated for the motions suites to match with the target spectrum, may have potential influence on the intra-suite variability and especially, the higher the scaling factor, the more scattered the nonlinear response results. To investigate shortly this finding, Fig. 7 plots the scaling factors of the 20 suites used in this study (i.e., 10 suites from each ranking system) versus the corresponding intra-suite variability estimates, quantified by the use of the COV for the top displacement values (along x-x and y-y direction). It is interesting to observe that a nearly linear trend was found between the intra-suite variability and the scaling factors of the suites; hence, one can claim that the higher the scaling factors used to form the suites, the higher the variability (i.e., the lower the reliability) of the response results. This finding, though, needs deeper investigation to reach rigid conclusions.

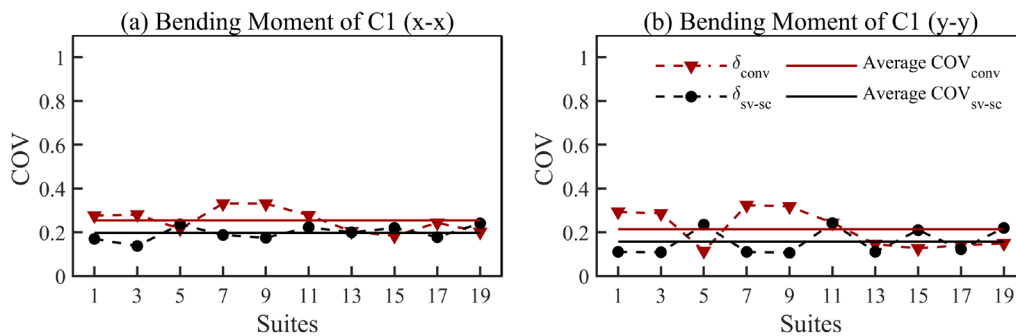

Fig. 5 – Intra-suite variability of force-based EDPs derived from nonlinear RHA with the use of 10 motions suites ranked according to the δ_{sv-sc} and δ_{conv} respectively.

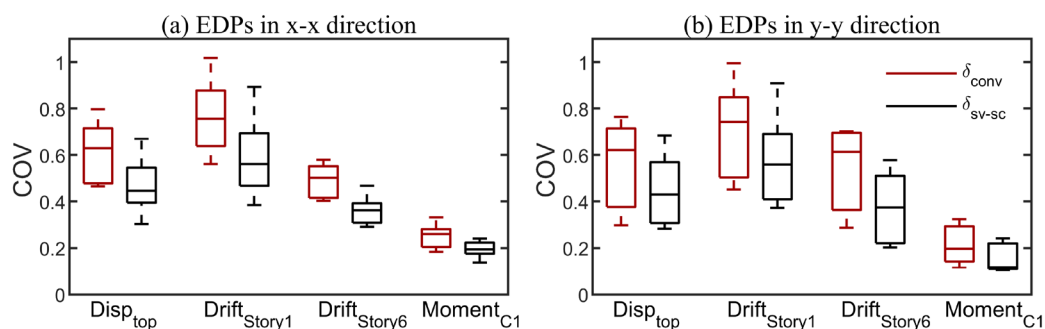

Fig. 6 – Boxplots of the intra-suite variability of both displacement and force-based EDPs derived from nonlinear RHA with the use of 10 motions suites ranked according to the δ_{sv-sc} and δ_{conv} respectively.

It is also notable that the intra-suite variability for the top three δ_{sv-sc} -ranked suites, being the profound choice for a designer, is significantly lower than the response variability that is related to the top three δ_{conv} -ranked suites (Figs. 4 and 5). The latter, found to be valid irrespectively of the EDP considered, highlights



the efficiency of the structure-specific selection and scaling of earthquake records [20] to prioritize motions suites that are associated with low intra-suite variability even in case of dealing with nonlinear response results. For example, the top δ_{sv-sc} -ranked suite led to COV for the interstory drift at the first story that is reduced by 55% compared to the intra-suite variability derived by the 1st δ_{conv} -ranked suite (Fig. 4).

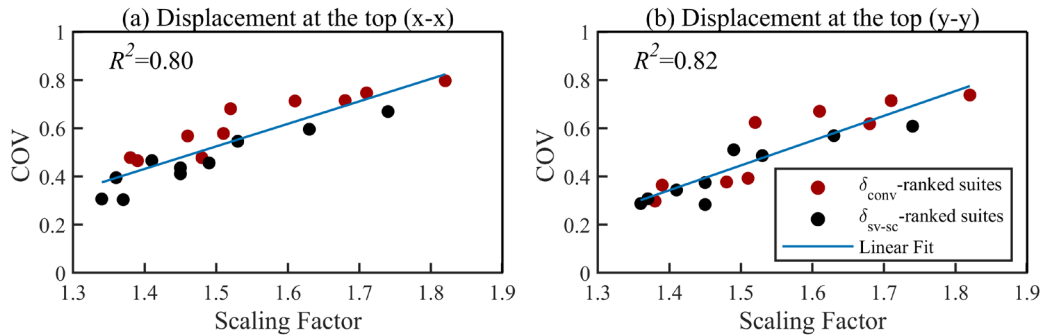

Fig. 7 – Relationship between the scaling factors of the formed suites and the corresponding intra-suite variability of the response results.

5. Conclusions

The current study assesses the performance of the structure-specific selection and scaling of earthquake records [20, 21], by focusing on the intra-suite variability of nonlinear response results. A multistory rc building, designed according to the modern Chinese regulatory framework, was modelled and a nonlinear RHA scheme was conducted with the use of motions suites ranked in the 1st, 3rd, 5th, 7th, 9th, 11th, 13th, 15th, 17th and 19th positions based on both the conventional, code-like approach, i.e., δ_{conv} , and the structure-specific one, i.e., δ_{sv-sc} . Several EDPs were used and their intra-suite variability, quantified via the COV, was calculated for those suites as a means to evaluate comparatively the efficiency of the two ranking systems in prioritizing suites that are related to reduced intra-suite variability. The latter is prerequisite to achieve increased reliability level for the average (design) response estimates, normally required during the code-prescribed design verification of structural systems. The main conclusions of the study are briefly summarized below:

- Considerably lower intra-suite variability of nonlinear response (i.e., 25% on average) was calculated when the case-study building was subjected to the δ_{sv-sc} -ranked motions suites instead of the ones prioritized by the conventional index.
- The latter was detected irrespectively on the EDPs adopted herein stressing, in such a way, the efficiency of the structure-specific selection and scaling of earthquake records in the case of nonlinear RHA.
- The scaling factor, calculated for the motions suites to match with the target spectrum, was found to have a linear relationship with intra-suite variability of the nonlinear analysis response results. Broader investigation is, though, required to reinforce the findings mentioned above accounting for different structural configurations, various seismic scenarios, multiple EDPs and wider set of motions suites.

6. References

- [1] Elnashai AS, McClure D (1996): Effect of modelling assumptions and input motion characteristics on seismic design parameters of RC bridge piers. *Earthquake Engineering & Structural Dynamics*, **25** (5), 435-463.
- [2] Katsanos EI, Sextos AG, Manolis GD (2010): Selection of earthquake ground motion records: A state-of-the-art review from a structural engineering perspective. *Soil Dynamics and Earthquake Engineering*, **30** (4), 157-169.



- [3] PEER GMSM Working Group (2009): Evaluation of ground motion selection and modification methods: predicting median interstory drift response of buildings. *PEER Report 2009/01*, Pacific Engineering Research Center, University of California, Berkeley, California.
- [4] EN1998 (2004): *Eurocode 8: Design of structures for earthquake resistance-part 1: general rules, seismic actions and rules for buildings*. CEN, Brussels.
- [5] ASCE 7-10 (2010): *Minimum design loads for buildings and other structures*. Reston, VA.
- [6] Hancock J, Bommer JJ, Stafford PJ (2008): Numbers of scaled and matched accelerograms required for inelastic dynamic analyses. *Earthquake Engineering & Structural Dynamics*, **37** (14), 1585-1607.
- [7] Kwon O-S, Elnashai A (2006): The effect of material and ground motion uncertainty on the seismic vulnerability curves of RC structure. *Engineering Structures*, **28** (2), 289-303.
- [8] Iervolino I, Manfredi G, Cosenza E (2006): Ground motion duration effects on nonlinear seismic response. *Earthquake Engineering & Structural Dynamics*, **35** (1), 21-38.
- [9] Baker JW (2011): Conditional mean spectrum: Tool for ground-motion selection. *Journal Of Structural Engineering*, **137** (3), 322-331.
- [10] Jayaram N, Lin T, Baker JW (2011): A computationally efficient ground-motion selection algorithm for matching a target response spectrum mean and variance. *Earthquake spectra*, **27** (3), 797-815.
- [11] Bradley BA (2010): A generalized conditional intensity measure approach and holistic ground - motion selection. *Earthquake Engineering & Structural Dynamics*, **39** (12), 1321-1342.
- [12] Luco N, Bazzurro P (2007): Does amplitude scaling of ground motion records result in biased nonlinear structural drift responses? *Earthquake Engineering & Structural Dynamics*, **36** (13), 1813-1835.
- [13] Cacciola P (2010): A stochastic approach for generating spectrum compatible fully nonstationary earthquakes. *Computers & Structures*, **88** (15-16), 889-901.
- [14] Huang Y-N, Whittaker AS, Luco N, Hamburger RO (2011): Scaling earthquake ground motions for performance-based assessment of buildings. *Journal Of Structural Engineering*, **137** (3), 311-321.
- [15] Sextos AG, Katsanos EI, Manolis GD (2011): EC8-based earthquake record selection procedure evaluation: Validation study based on observed damage of an irregular R/C building. *Soil Dynamics and Earthquake Engineering*, **31** (4), 583-597.
- [16] Reyes JC, Kalkan E (2012): How many records should be used in an ASCE/SEI-7 ground motion scaling procedure? *Earthquake spectra*, **28** (3), 1223-1242.
- [17] Araújo M, Macedo L, Marques M, Castro JM (2016): Code - based record selection methods for seismic performance assessment of buildings. *Earthquake Engineering & Structural Dynamics*, **45** (1), 129-148.
- [18] Dias J, Castro J, Romão X, Gonçalves M, Lopes JC (2010): SeleEQ: a web-based application for the selection of earthquake ground motions for structural analysis. *14th European Conference on Earthquake Engineering*,
- [19] Iervolino I, Galasso C, Cosenza E (2010): REXEL: computer aided record selection for code-based seismic structural analysis. *Bulletin of Earthquake Engineering*, **8** (2), 339-362.
- [20] Katsanos E, Sextos A (2018): Structure-specific selection of earthquake ground motions for the reliable design and assessment of structures. *Bulletin of Earthquake Engineering*, **16** (2), 583-611.
- [21] Katsanos EI, Sextos AG (2013): ISSARS: An integrated software environment for structure-specific earthquake ground motion selection. *Advances in Engineering Software*, **58**, 70-85.
- [22] Ministry of Housing and Urban-Rural Development of the People's Republic of China (2010): *Code for Seismic Design of Buildings (GB50011 - 2010)*. China Architecture and Building Press, Beijing, China.
- [23] General Administration of Quality Supervision (2015): *Seismic Ground Motion Parameters Zonation Map of China (GB18306 - 2015)*. Standards Press of China, Beijing, China.



- [24] Ministry of Construction of the People's Republic of China (2010): *Code for Design of Concrete Structures (GB 50010-2010)*. China Building Industry Press, Beijing, China.
- [25] Guo Y, Gong G, Chin C, Zhang C (2018): Structural design of concrete to EC2 and GB50010-2010: a comparison. *MATEC Web of Conferences*, **175** 01039.
- [26] FEMA 450 (2003): *NEHRP recommended provisions for seismic regulations for new buildings and other structures - part 1: provisions*. Building Seismic Safety Council for the Federal Emergency Management Agency, Washington, DC
- [27] Wen R, Ji K, Ren Y (2018): The Real Grond Motion Rcrds Selection for Seismic Design Code in China. *16th European Conference on Earthquake Engineering*,
- [28] Beyer K, Bommer JJ (2007): Selection and scaling of real accelerograms for bi-directional loading: a review of current practice and code provisions. *Journal of earthquake engineering*, **11** (S1), 13-45.
- [29] Buratti N, Stafford PJ, Bommer JJ (2011): Earthquake accelerogram selection and scaling procedures for estimating the distribution of drift response. *Journal Of Structural Engineering*, **137** (3), 345-357.