



DESIGN OF A HIGH-PERFORMANCE HEXAPOD TO MEET THE REQUIREMENTS IN THE LATEST SEISMIC QUALIFICATION CODES

A. Sextos⁽¹⁾, A.J. Crewe⁽²⁾, M. Dietz⁽³⁾, G. Wardrop⁽⁴⁾

⁽¹⁾ Professor, University of Bristol, UK, a.sextos@bristol.ac.uk

⁽²⁾ Reader, University of Bristol, UK, a.j.crewe@bristol.ac.uk

⁽³⁾ Research Fellow, University of Bristol, UK, m.dietz@bristol.ac.uk

⁽⁴⁾ Systems Engineering Manager, Servotest Systems, UK, glen.wardrop@servotestsystems.com

Abstract

Hinkley Point C (HPC) is one of two new-build European Pressurised Reactors (EPR) that EDF are to construct in the UK. While UK seismic risk is relatively low, the seismic design of the power station structures and the included mechanical and electrical equipment is nevertheless key to the whole design process. This paper focusses on the requirement for seismic qualification of all the equipment to be installed within Hinkley Point C. While much equipment may be qualified via numerical modelling or comparison with similar pre-qualified equipment, a significant proportion falls out of the scope of these methodologies and can be qualified by laboratory testing only, usually using a shaking table. The seismic qualification test requirements describes two routes for qualifying equipment based on whether the equipment is an assembly (equipment mechanically coupled to the plant structure directly i.e. without any intermediate assembly structure) or a component (equipment mechanically coupled to the plant structure by means of an intermediate assembly/support fixture). For the assembly testing, the test spectra has a peak spectral acceleration of 6g and a Zero Period Acceleration (ZPA) value of 1.2g, a readily achievable level for many shaking tables worldwide. However, the component testing spectra is particularly onerous with a peak spectral acceleration of 35g and a ZPA value of 7g. Clearly, this level of testing is well beyond what is achievable on the conventional shaking tables used for seismic testing.

To meet the very high test levels defined for component testing, the University of Bristol has worked with Servotest Systems to design and manufacture a 6 DoF Hexapod shaking table that can deliver the required performance levels. The system was designed to be initially installed in the Bristol Laboratories for Advanced Dynamics Engineering (BLADE) at the University of Bristol. In 2021, the system is to be relocated to the University of Bristol's new National Soil Structure Interaction Facility where it will benefit from the greater hydraulic power supply of that facility. In its initial location, the Hexapod can meet the HPC component test spectra in 2 axes simultaneously and once relocated it will be able to deliver the same performance triaxially.

This paper describes in detail the modelling and simulation of the new table, and the design, installation & commissioning of the system in its initial location giving examples of the performance achieved. It also presents some results from the first tests performed on this high-performance shaking table.

Keywords: shaking table; seismic qualification; nuclear power; non-structural components



1. Introduction

Earthquake and other dynamic loads effect not only civil engineering structures but also all the equipment and plant contained within them. These artefacts therefore need to be designed so that they can withstand these seismic loads and not experience any damage or change in operation during an earthquake. The process for assessing the performance of equipment in a seismic event is generally described as ‘Seismic Qualification’, and may include analysis, physical testing and reference to databases of similar equipment that have been previously qualified. Seismic qualification is therefore a core activity within the nuclear and telecommunication industries, and is equally important in other safety and mission critical industries that must cater for earthquake and other severe dynamic environmental loads.

An important practical application of shaking tables is seismic qualification testing of electro-mechanical plant. This usually involves shaking the equipment with simulated earthquakes to prove its safe operation during and after a seismic event. Each input seismic motion lasts about twenty seconds and the sequence of shaking is carefully designed to give a realistic test of the equipment under different levels of shaking, including cumulative damage effects. In most cases the final test is at an intensity of shaking 1.4 times greater than the full design earthquake to prove that the equipment is not on the verge of failure at the design earthquake level. After each shake, each item is carefully inspected, and functional tests are carried out. This type of equipment testing is particularly important when the equipment is part of a safety critical operation, as is the case for nuclear facilities, and is therefore part of the design process for all mechanical and equipment in nuclear power stations in the UK.

2. Seismic Qualification test codes used in the UK

A number of seismic qualification test specifications are currently in use in the UK for testing equipment to be installed/replacing existing equipment in nuclear power stations and in other safety critical systems.

Examples of such test codes include:

- BELCORE – NEBS, NEBSTM Requirements: Physical Protection, Telcordia Technologies Generic Requirements, GR-63-CORE Issue 2, April 2002 [1]
- IEC 60068-2-57, International Test Standard, Environmental testing, Part 2-57: Tests – Test Ff: Vibration – Time-history method [2]
- IEC 60068-3-3, International Test Standard, Environmental testing, Part 3-3: Guidance – Seismic test methods for equipment [3]
- ETSI EN 300 019-2-3 V2.2.2 (2003-04), European Standard (Telecommunications series), Environmental Engineering (EE); Environmental conditions and environmental tests for telecommunications equipment; Part 2-3: Specification of environmental tests; Stationary use at weatherprotected locations [4]
- IEEE-344-2013. IEEE Standard for Seismic Qualification of Equipment for Nuclear Power Generating Stations [5]
- IEEE-693-2018. Recommended practice for the seismic design of substations.
- BTR 91C112.00. Book of Technical Rules, Equipment earthquake resistance test - Generic provisions for the biaxial time history test [6]

All of these codes define a sequence of tests and define the levels of excitation that the equipment must be subjected to. The codes also define the duration of strong motion, and in some cases define the number of high acceleration peaks that the time history should contain.

BTR (Book of Technical Rules) 91C112.00 [6] is one of the main documents that define seismic qualification testing procedures for equipment going into existing nuclear power stations in the UK. This document states that the test time histories are synthesised in accordance with the guidelines in IEC 60068-2-57 [2] with an overall duration of 20 seconds and a strong motion duration of at least 10 seconds. The number of high peaks of the response must be at least 8 (for a threshold value of 70%) and for a given biaxial test, time



histories used on the horizontal axis and the vertical axis must have a correlation coefficient less than 0.1. The time histories also need to be created to match the defined spectra at 1/6 octave points, assuming that the damping value is greater than 2%. This BTR [6] also defines:

- **components** as equipment mechanically linked to civil engineering by means of an intermediate assembly structure and gives examples as: electro-valve equipment, recording equipment, valve motorisations, electromagnetic relays. The BTR also notes that valves that are not directly linked to civil engineering and for which the intermediate assembly structures cannot be included in the test assembly are considered as devices. This is especially the case of valves that are mounted at points distant from the pipe run fastenings.
- **assemblies** as equipment directly linked mechanically to the plant's civil engineering without any intermediate assembly structure and gives the example of cabinets. The BTR also notes that when the valves are mounted on the pipe runs at one of the points where they are fastened to civil engineering, then the valves can be considered as an assembly.

The BTR then goes on to define some spectra for these two types of item and a comparison between the horizontal spectra for components and assemblies can be seen in Fig.1.

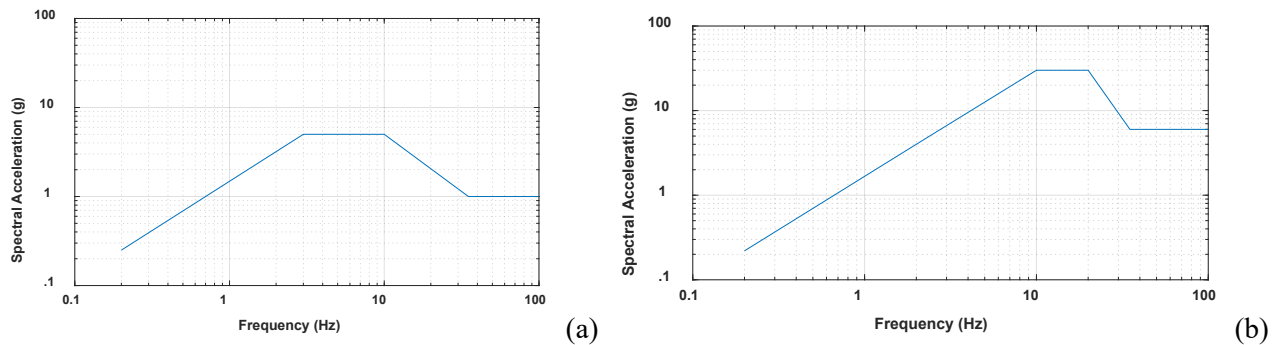

Fig. 1 – BTC 91C112.00 Horizontal Spectra; (a) Assemblies; (b) Components [6].

The “assembly” test spectra (Fig. 1a) is relatively low level and can be achieved on many shaking tables. The “component” spectra (Fig. 1b) however would require a much more powerful system but, to date, has rarely been specified for equipment being retrofitted into existing UK power stations.

2.2 Hinkley Point C test specification

The seismic qualification test specification defined by EDF for equipment to be installed in the new Hinkley Point C (HPC) nuclear power station is a further document [7] that supplements BTR 91C112.00 [6] providing, in particular, new spectra that are to be applied to equipment at different locations in the power station. These supersede the BTR 91C112.00 defined spectra shown in Fig. 1.

The HPC specification continues to describe two routes for qualifying equipment based on whether the equipment to be qualified, as defined above, is an assembly (equipment directly coupled mechanically to the plants' structure without any intermediate assembly structure e.g. cabinets) or a component (equipment mechanically coupled to civil engineering structures by means of an intermediate assembly/support structure e.g. electro-valve equipment, monitoring equipment, motorized valves, electromagnetic relays). However, the peak defined spectra for both types of test items are higher and the frequency range broader than defined in BTR 91C112.00 [6].

The component testing spectra is particularly onerous with a peak spectral acceleration of 35g and a ZPA value of 7g, and this level of testing is well beyond that achievable on normal shaking tables that operate at the low frequencies (0-100Hz) needed for seismic testing. Therefore, in order to meet the demand for seismic qualification of components to be installed in HPC, the University of Bristol collaborated with shaking table manufacturer Servotest Systems to design a shaking table system that was capable of meeting this component level test.



3. Design of a very high-performance shaking table

In order to meet the very high test levels defined for component testing, Bristol University has worked with Servotest Systems to design, manufacture and install a very high performance 6 DoF shaking table that can deliver the required performance levels for HPC component level testing. Initially, several 8 actuator arrangements, typical of most seismic shaking tables, were considered one such example being shown in Fig.2. However, these designs were bulky, requiring a significant amount of steelwork to support the ends of the actuators. Therefore, some less traditional actuator arrangements (at least for seismic shaking tables) were considered, with one early 6 axis configuration shown in Fig. 3.

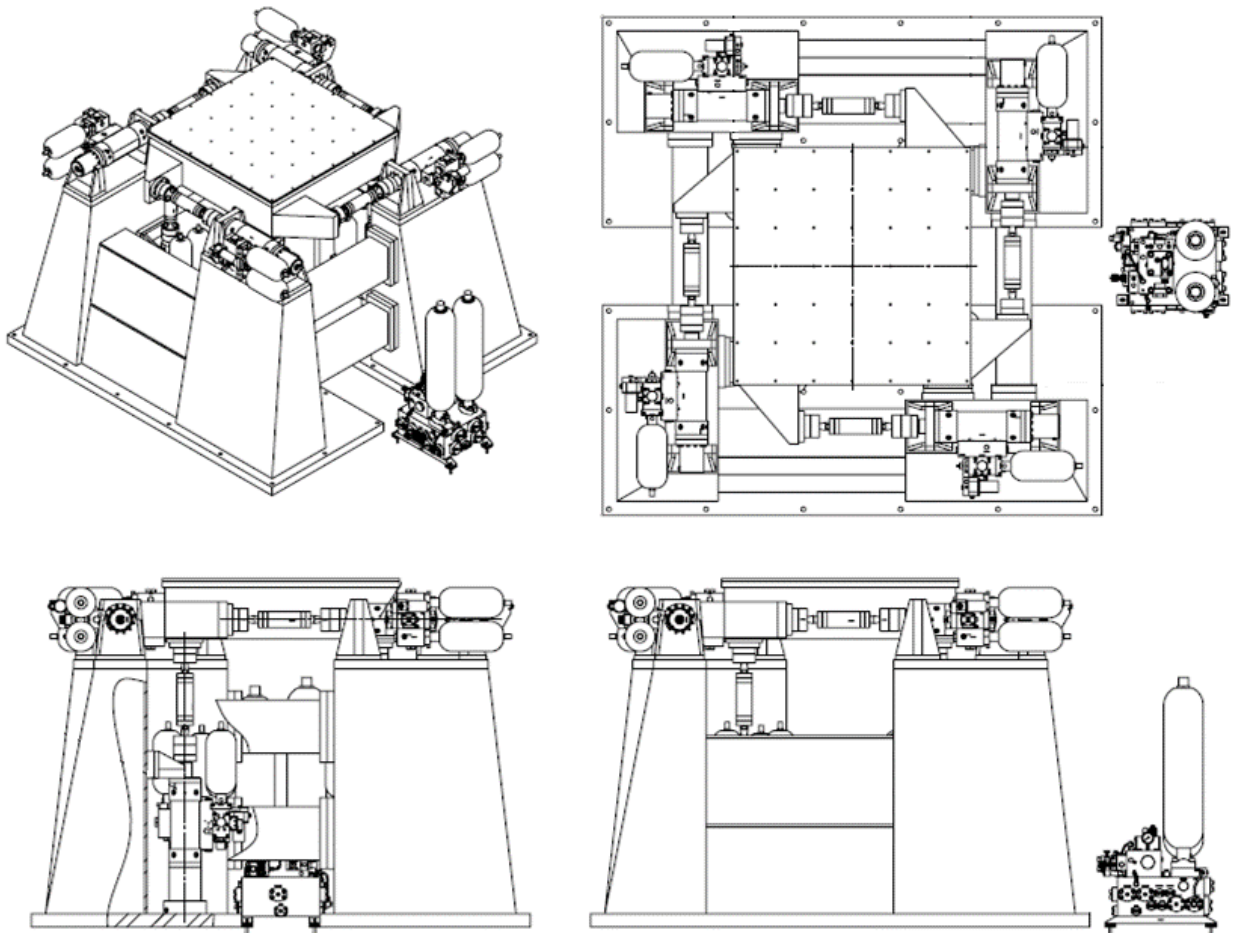

Fig. 2 – Eight actuator table arrangement.

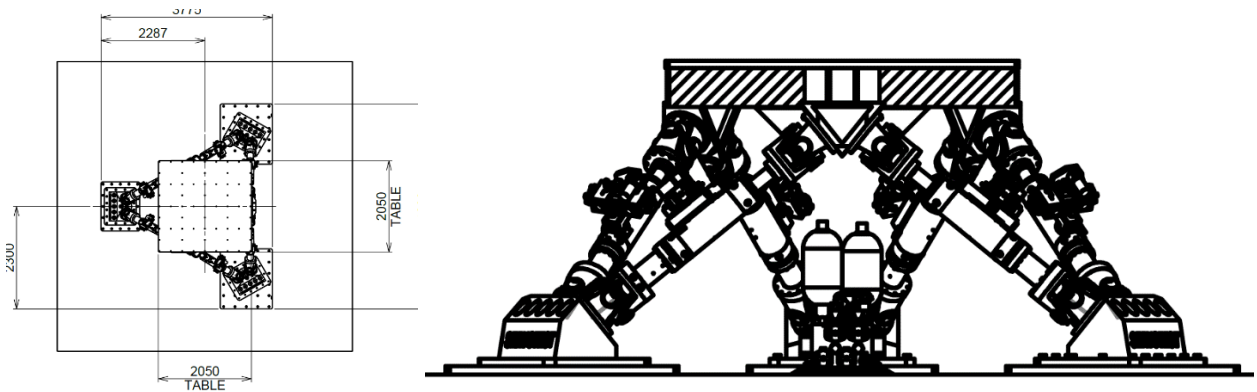

Fig. 3 – Six actuator table arrangement.



While this type of 6-actuator (Hexapod) configuration can be considered not to be ideal, because the actuators are not symmetrical to the main shaking table axes and the kinematics of the system mean that there is significant coupling between the shaking table axes, the physical configuration of the actuators lends itself to simple base plate mounting and a more direct force path for the actuators into the foundation.

3.1 Modelling and Simulation of the Hexapod shaking table

In order to fine tune the design of the Hexapod, Servotest Systems developed a complete model of the system (Fig. 4) to allow optimization of the geometry of the actuators and to test the performance of the system, including the oil demand. The oil demand was critical to the design because initially the shaking table was to be installed in the existing shaking table laboratory in Bristol, which only has an oil flow of 900 litres/min @ 205/230 bar. However, in 2021 the Hexapod will be moved to a new National Soil Structure Interaction Facility [8] that is built in the framework of the UK Collaboratorium for Research on Infrastructure and Cities where a peak oil flow of 1500 litres/min @ 280 bar will be available, thus significantly increasing the performance of the Hexapod.

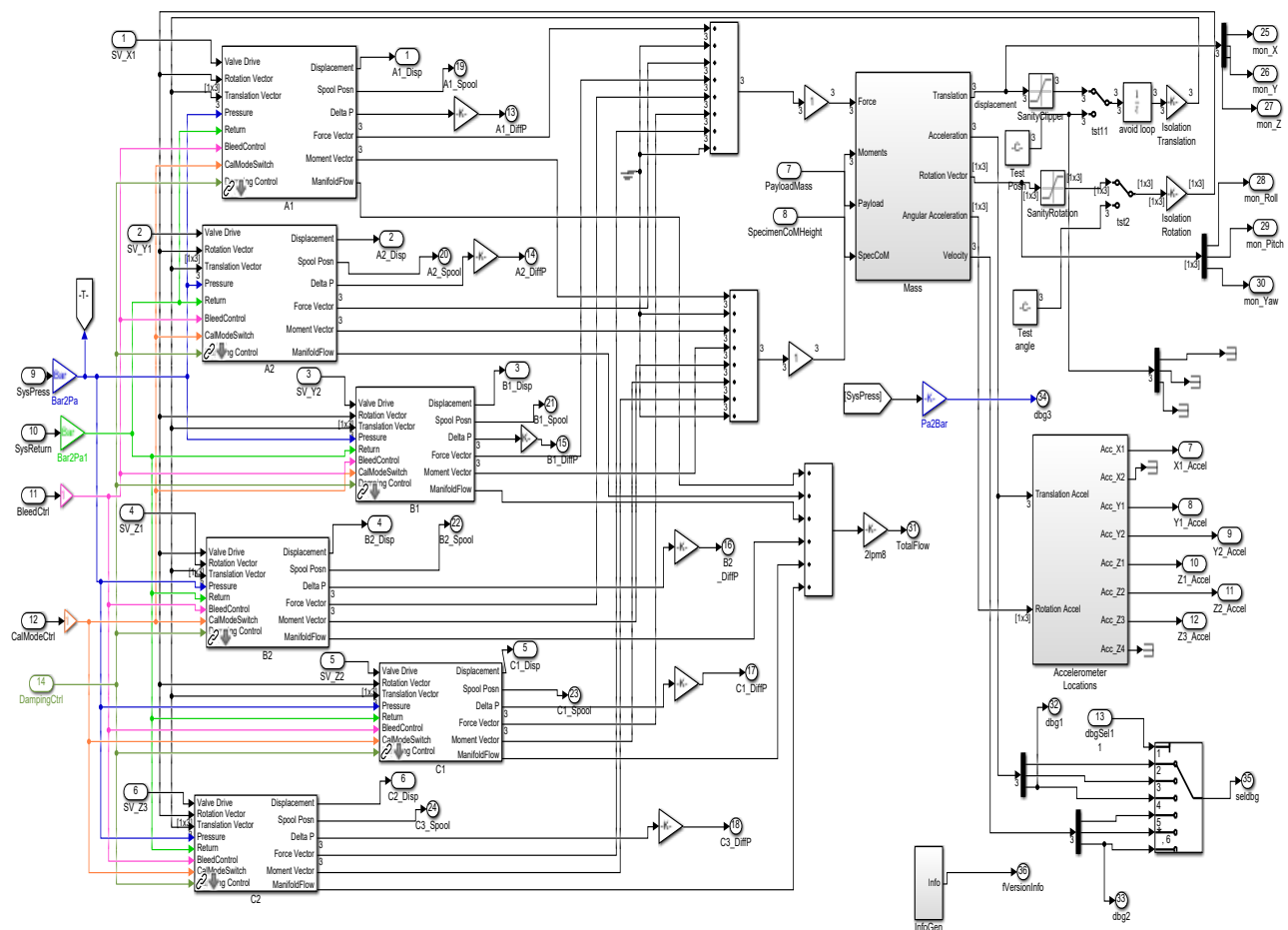

Fig. 4 – Mathworks Simulink - Hexapod system simulation.

In parallel with the system design significant effort was put into the design of the Hexapod platform to reduce unwanted resonances while at the same time minimizing the platform mass to allow the Hexapod to carry the highest possible specimen mass while still maintaining its performance. The final design for the platform comprises a circular waffle cell structure based on a radial grid with additional stiffening, where the actuators connect to the platform (Fig. 6).

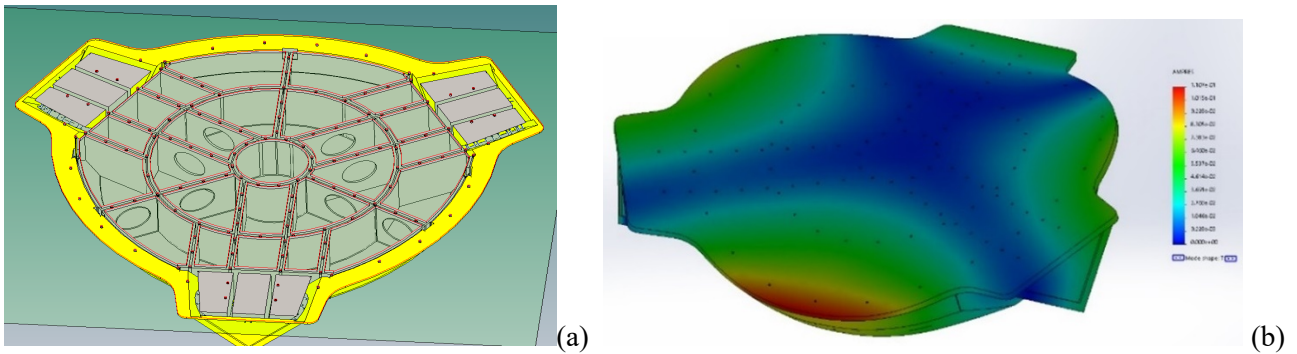

Fig. 6 – (a) Waffle cell structure of Hexapod platform; (b) FE modal analysis of the platform.

The final design of the hexapod is shown in Fig. 7 along with the bolt pattern for fastening specimens to the table in Fig 8. Because this bolting pattern follows an unusual radial grid a number of small sacrificial adapter plates have been designed to allow simpler mounting of rectangular specimens onto the Hexapod.

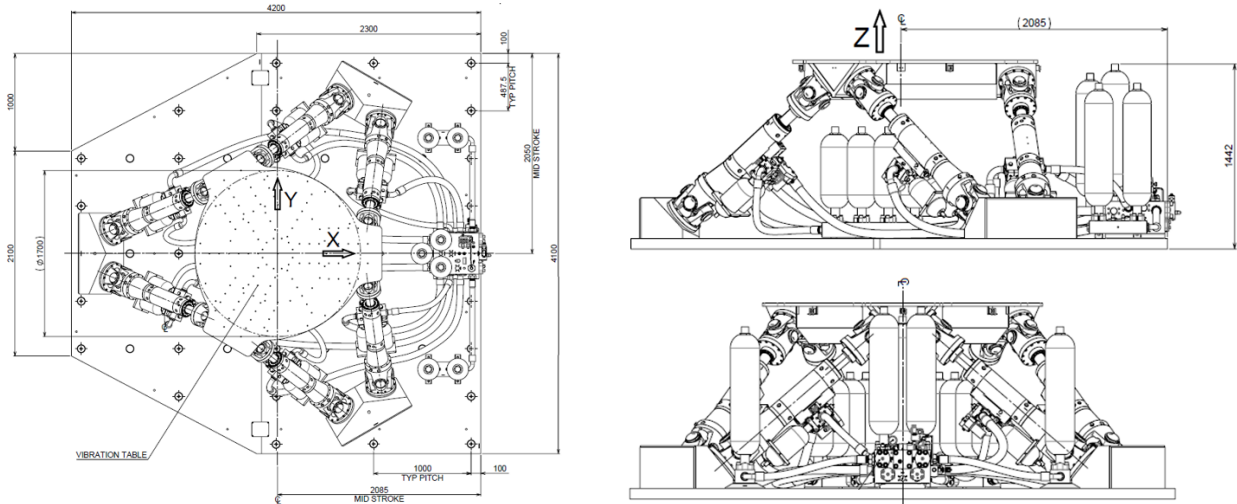

Fig. 7 – Final design of the Hexapod - Plan and elevations

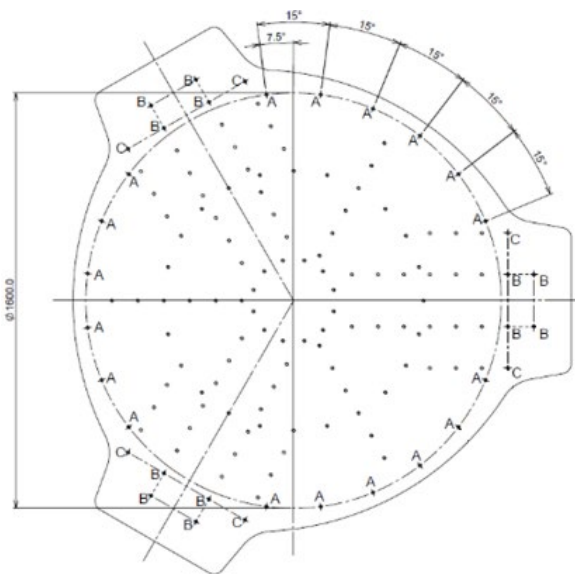

Fig. 8 – Bolt pattern in top of table – following a radial grid



4. Installation and commissioning

Before installation of the Hexapod on site there was a lot of careful planning to ensure that bolting down arrangement and the hydraulic interfaces with the existing ring main would be correct. A 3D model (Fig. 9a) was used to plan the installation and this meant that no problems were encountered during the 3-day installation of the system. The final installation, including protection barriers, is shown in Fig. 9b.

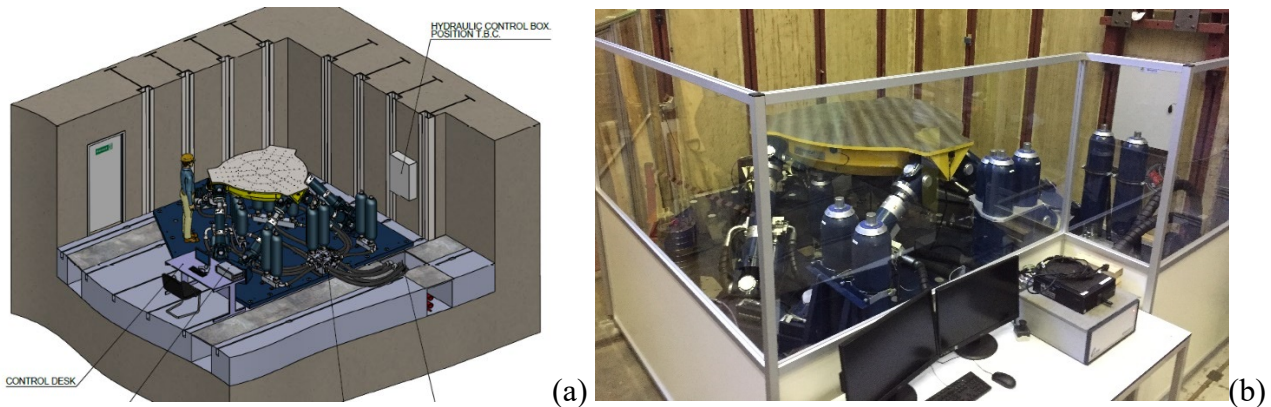

Fig. 9 – (a) 3D model use to plan installation; (b) Final Installation

Following the installation there was a week of commissioning and acceptance testing. The performance of the table was assessed initially with no payload but following this an adjustable mass with a high centre of gravity (Fig. 10) was used to test the limits of the table performance and the control system.

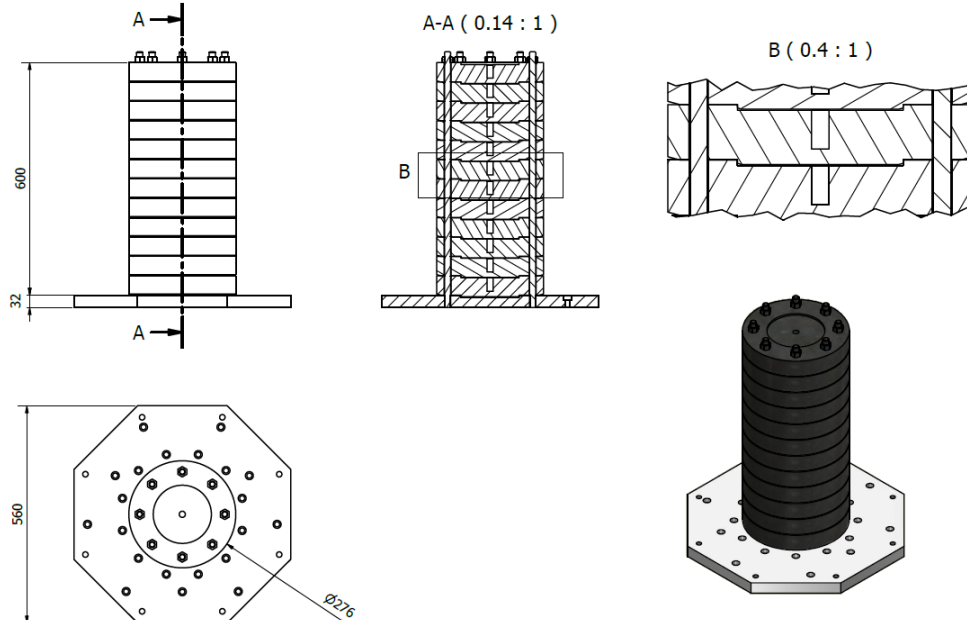

Fig. 10 – Adaptable commissioning model used to test table performance.

The commissioning and acceptance tests included simple kinematic tests and sine wave reproduction tests but mostly focused on the ability of the control system to reproduce time histories that matched the HPC response spectra [7]. The Hexapod control system is split into two main components, namely, (a) a basic user interface that allows quick control of simple table motions and allows monitoring of accelerations, displacements etc. of the table (Fig. 11a) and (b) some software that allows iterative matching of time histories and adjusts the control signals to compensate for the system dynamics, thus allowing accurate reproduction of time history motions on the table (Fig. 11b).

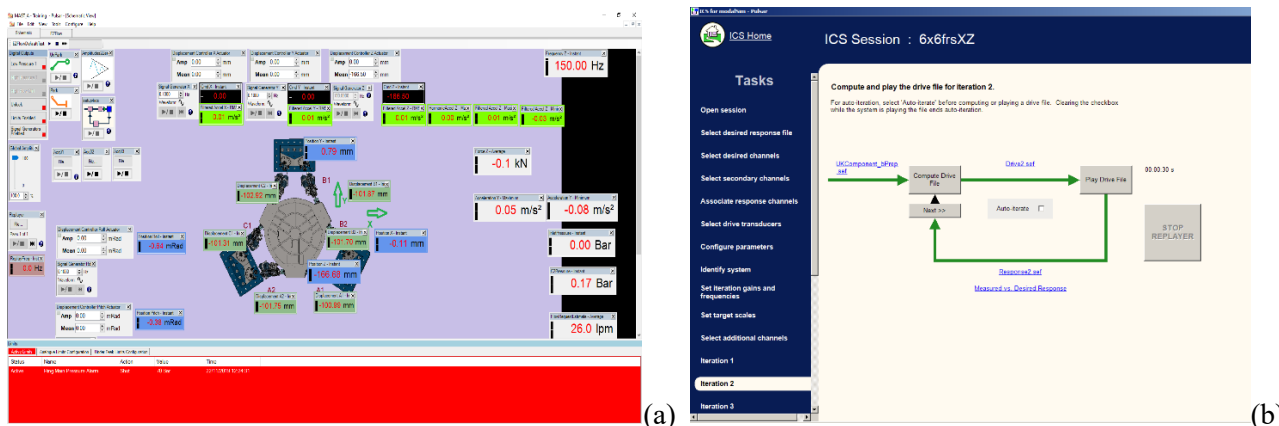

Fig. 11 – (a) Hexapod User interface; (b) Iteration software for matching time histories on the Hexapod.

The performance of this iterative matching process is particularly important when there is the possibility of significant interaction between the specimens being tested and the shaking table system. For a Hexapod arrangement of actuators, the control of overturning is particularly challenging because the line of action of forces for the actuators is all below the center of gravity of the platform. The commissioning model with its high center of mass then made the control even more challenging. The first step in the matching process is the generation of an artificial time history. For the commissioning tests this was done using software developed by Servotest but a number of methods exist for creating spectrum compatible time histories and the Hexapod control system will also allow a time history generated using any other method (e.g. [9] & [10]) to be used as the target time history. An example of an artificial time history generated to meet the HPC component test spectra above 2.5Hz is shown in Fig. 12. In this case the peak displacement of the motion is 56mm and the peak velocity is just below 2m/s and this time history has been optimized to reduce the peak demand for oil during the shake. Fig 12 shows that the software has been able to create a target time history that envelopes the target RRS nicely at all frequencies above 2.5Hz with very little over enveloping using a compression algorithm. The compression algorithm helps reduce the peak accelerations while maintaining the spectral matching reducing over enveloping at high frequencies.

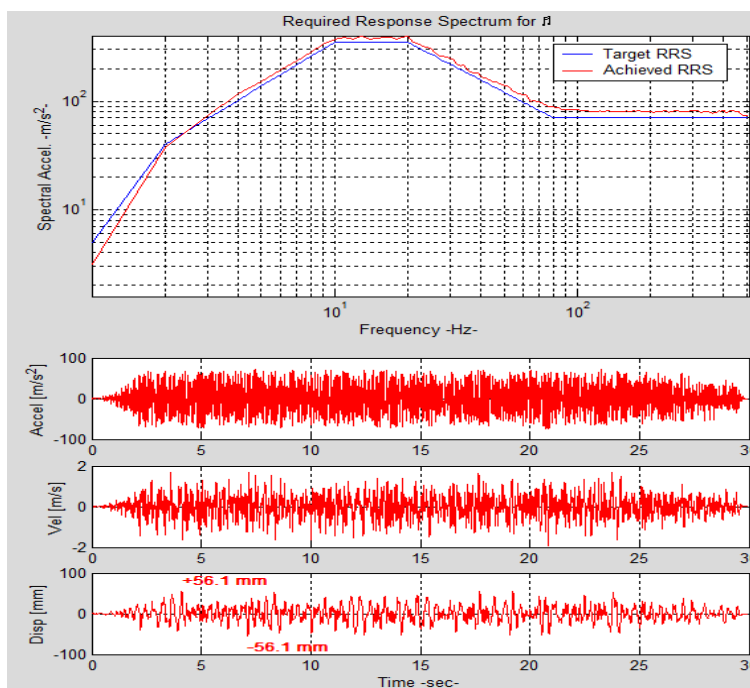

Fig. 12 – Output from time history generation software



Once the target time history has been defined the iteration software can start the process of calculating and then adapting the drive signals to each of the actuators such that the table produces the required target motions. Fig. 13 shows the progress of this iteration process over 11 iterations (each of which takes about 60 seconds). Fig. 13a shows the %RMS error between the target and desired motions of the table and it is clear that the errors very quickly reduce to an acceptable level. Fig. 13b further shows the convergence of the RMS accelerations in the two main test axes to desired values.

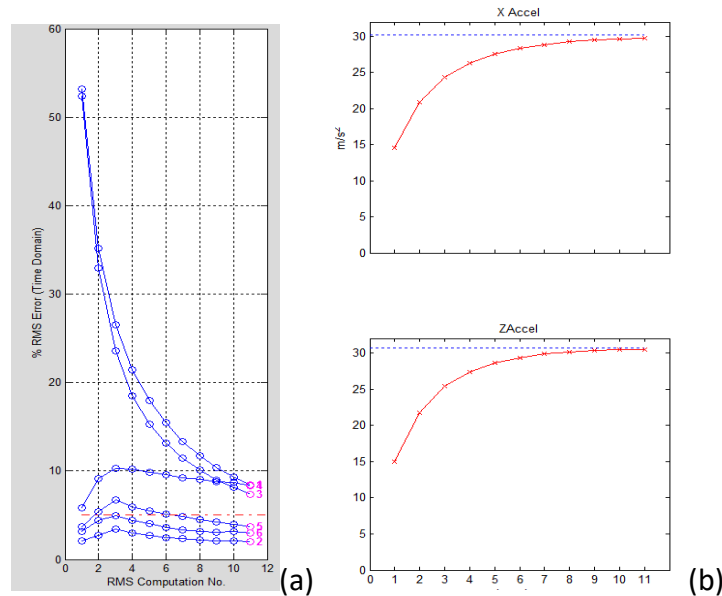

Fig. 13 – Convergence of the iteration process

Fig. 14a shows the final result of this iterative matching process as a comparison between the original RRS test spectra (grey), the RRS for the target time history (blue) and the RRS for the achieved time history (pink). It is clear from this figure that the control software has done an excellent job and the RRS of the actual and desired tables motions are almost identical. Fig. 14b shows a comparison of the Power Spectral Densities (PSDs) for the desired and actual table response where the table is showing excellent performance up to 100Hz.

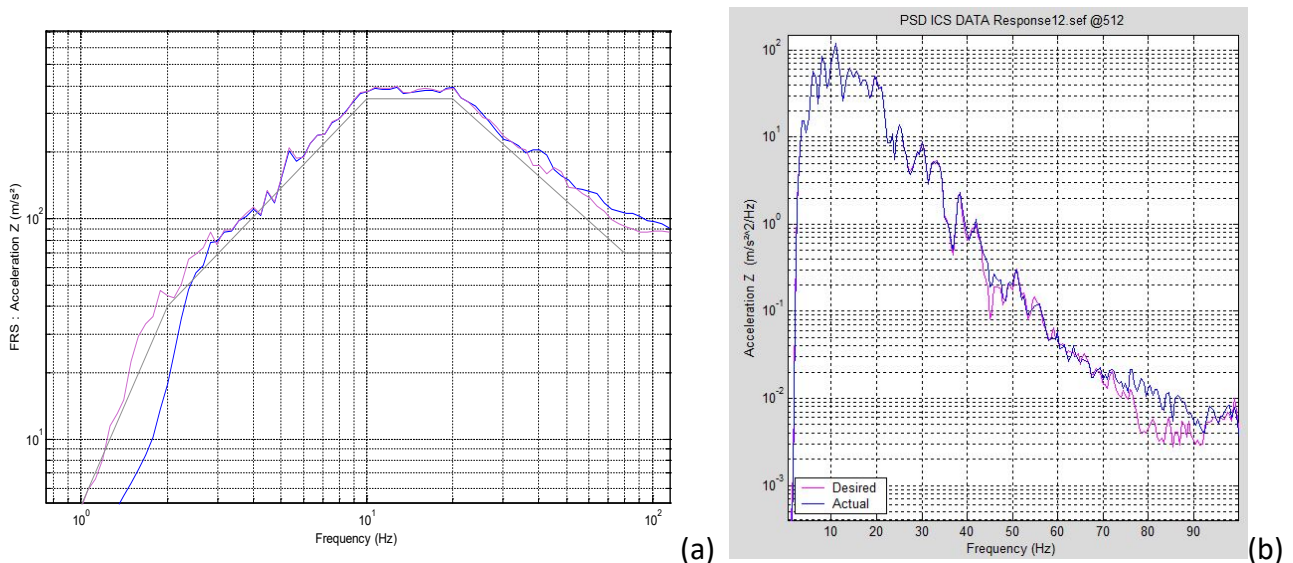

Fig. 14 – Target and achieved (a) RRS, (b) PSD after iterative matching process



For completeness, Fig. 15 provides a comparison between the target and achieved time histories for a 2 sec portion of the table motion revealing only minor deviations between the two motions in the time domain. The coherence data and coupling between axes for a typical commissioning test is shown in Fig. 16. The conference plot for the individual axes (Fig 16a) shows strong coupling between individual axis drive and demand signals. In Fig. 16b the inverse system matrix after the system identification process is shown and it is clear that the non-diagonal terms are very small showing that there is very little coupling between the table axes.

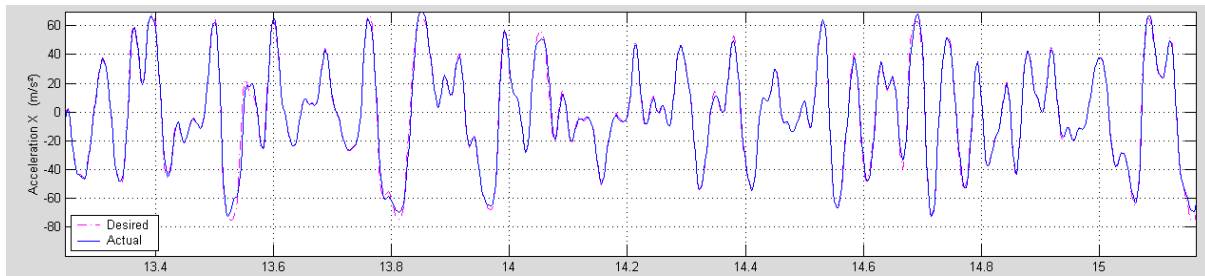

Fig. 15 – Target and achieved time histories.

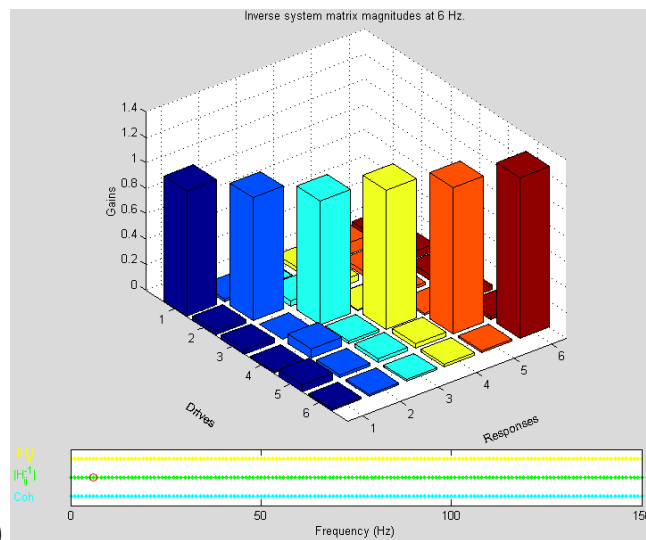
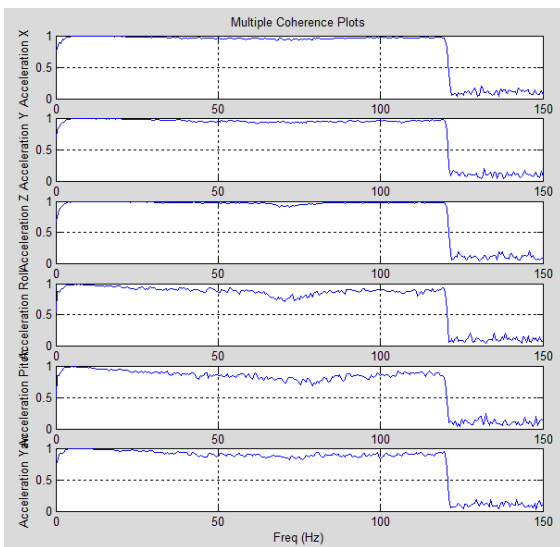

Fig. 16 – (a) Coherence functions for the 6 Hexapod axes; (b) inverse system matrix after system identification.

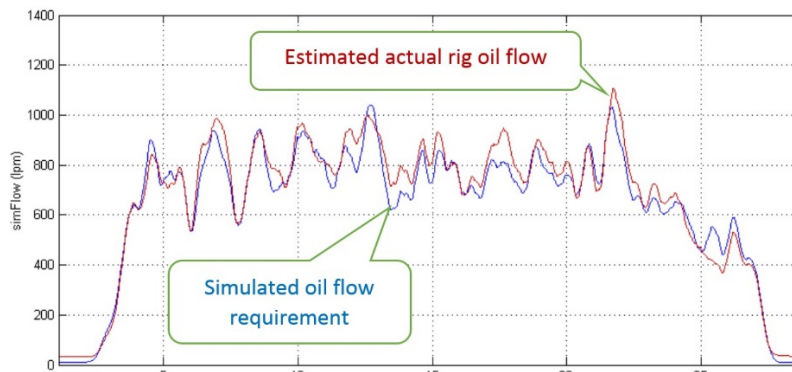

Fig. 17 – Oil flow requirement, (Blue) Simulated, (Red) Actual measured.



Because Hexapod is currently installed in a temporary location, where the oil supply is not as high as desirable, a key part of the commissioning process was identification of any limitations in performance resulting from the reduced oil flow and oil pressure available. The specification of the Hexapod took this into account by setting different maximum performance levels for when the table is installed in each location. A comparison between the anticipated and actual oil flows for a two axis HPC component test motion can be seen in Fig. 17. At the start and end of the shake some small offsets can be seen, and these indicate that there was a slightly higher leakage flow than simulated on the Hexapod. It is also clear that even though the laboratory hydraulic supply has a peak flow of on 900 l/min the small bank of accumulators by the Hexapod allows a higher instantaneous flow up to 1200 l/min. This means that in the current laboratory the Hexapod is able to meet the HPC component test spectra in 2 axes simultaneously or reach 70% of the RRS as a triaxial shake. Once the Hexapod is relocated it will easily be able to deliver a triaxial shake meeting the defined RRS levels at 100%. A summary of the current Hexapod performance is shown in Table 1.

Table 1 – Performance of Hexapod as currently installed

Platform size	1.2m by 1.2m	
Controllable axes:	6 (X, Y, Z, Roll, Pitch, Yaw)	
Platform mass:	1t	
Maximum payload:	~300kg	
Headroom:	12m	
Maximum height of payload c of g	2m	
Craneage capacity	2 x 10t tandem cranes, 1 x 5t jib crane for lab access	
No. of servo hydraulic actuators	6 in hexapod arrangement	
Performance	Vertical	Horizontal
Capacity of actuators	144kN	144kN
Max. acceleration (no payload)	13g	13g
Max. acceleration (800kg payload)	>8g	>8g
Actuator stroke	+/- 100mm	+/- 100mm
Max. translational velocity	2 m/s	2 m/s
Bandwidth	0-100Hz	
Hydraulic supply	900 litres/min @ 205/230 bar, being increased to 1500 litres/min @ 280 bar in new lab	

5. Conclusions

A very high performance Hexapod shaking table designed by Servotest Systems has been installed at Bristol University that can meet the component level test specification defined in the most recent HPC seismic qualification specification. The Hexapod can reproduce time histories with a peak spectral acceleration of 35g and a Zero Peak Acceleration (ZPA) value of 7g with an operating frequency range of 0Hz to >100Hz. The system is currently installed in the existing shaking table laboratory at Bristol University and will be relocated at the new National Soil Structure Interaction Facility at Bristol University once this is completed in 2021. The Hexapod table will then benefit from the 2000 l/min oil supply. In its initial location the Hexapod is able to meet the HPC component test spectra in 2 axes simultaneously and once relocated it will be able to deliver the same performance as a triaxial shake.



6. References

- [1] GR-63-CORE (2002). Network Equipment-Building System (NEBS) requirements: Physical Protection Telcordia Technologies. GR-63- CORE Issue 2, April 2002
- [2] IEC 60068-2-57, International Test Standard, Environmental testing, Part 2-57: Tests – Test Ff: Vibration – Time-history method
- [3] IEC 60068-3-3:1991, International Test Standard, Environmental testing, Part 3-3: Guidance – Seismic test methods for equipment
- [4] ETSI EN 300 019-2-3 V2.2.2 (2003-04), European Standard (Telecommunications series), Environmental Engineering (EE); Environmental conditions and environmental tests for telecommunications equipment; Part 2-3: Specification of environmental tests; Stationary use at weatherprotected locations
- [5] IEEE-344-2013. IEEE Standard for Seismic Qualification of Equipment for Nuclear Power Generating Stations
- [6] Book of Technical Rules - Equipment earthquake resistance test – Generic provisions for the biaxial time history test. BTR 91 C 112 EN Revision 00. EDF. 2010
- [7] EPR UK HPC – Contractual Specification for Seismic and Vibration testing on electrical equipment. HPC-SEPTEN-XX-ALL-SPE-200155, Rev A. EDF. 2016
- [8] Taylor CA, Crewe AJ, Mylonakis G. (2016): Towards very large scale laboratory simulation of structure-foundation-soil interaction (SFSI) problems. 1st IMEKO TC4 International Workshop on Metrology for Geotechnics, MetroGeotechnics 2016. IMEKO-International Measurement Federation Secretariat. pp. 1-6
- [9] Crewe AJ (2012): Generation of Improved Artificial Earthquakes for Seismic Qualification Testing. 15th World Conference of Earthquake Engineering, Lisbon. Paper No 1353 ed. CD, 10 p.
- [10] Alexander NA, Chanerley AA, Crewe AJ & Bhattacharya S (2015): A novel approach to producing spectrum compatible ground motions using Volterra series. SECED 2015 Conference - Earthquake Risk and Engineering towards a Resilient World., Cambridge, United Kingdom, 6/07/15.