

# A STRONG MOTION RADIO TELEMETRY NETWORK

by

J. Prince<sup>I</sup>, H. Rodriguez<sup>I</sup>, E. Z. Jaworski<sup>II</sup> and G. Kilander<sup>II</sup>

## SYNOPSIS

A total of 58 seismic signals from 16 sites in Mexico City and surrounding areas are multiplexed, transmitted through six radio channels to a central station and recorded continuously with a common time base on two tape recorders which automatically alternate in operation. There are 36 low and 18 high sensitivity ground acceleration signals and four from vertical seismometers. The system is designed to operate through major earthquakes and commercial power failures. Four drum recorders provide standard seismograms, and acceleration signals can be recovered on or off-line for digitization and further processing.

## 1. INTRODUCTION

As in many other seismic countries, the recording of strong motion earthquakes has been the object of a continued effort in Mexico during the last decade. The first accelerograph was put in operation in 1961 and by the end of 1972 fifty such instruments have been installed with the sponsorship of several government agencies and the National Autonomous University of Mexico which, through its Institute of Engineering, is in charge of operation and maintenance of almost all of them.

In order to add a significant number of instruments in a relatively short time, and to conduct several other studies in the Earthquake Engineering field, a proposal was submitted to UNESCO and the United Nations Development Program (UNDP) in 1965 to undertake a Soil Dynamics Project that included provisions for a substantial number of strong-motion recording stations. This Project, jointly sponsored by the Mexican Government and UNDP, was officially started by mid-1971. One of the first studies to be initiated was the design of the seismic radio telemetry network which is described in this paper.

## 2. GENERAL DESIGN CRITERIA

Once the economic constraints were defined, the main problem was to

I Research Professor, School of Engineering, National Autonomous University of Mexico, Mexico City.

II UNESCO Expert, Soil Dynamics Project, National Autonomous University of Mexico, Mexico City.

reach a reasonable compromise between estimated construction and maintenance costs on the one side and, on the other, number, quality and location of stations as well as the expected quantity and usefulness of data to be obtained.

The following were adopted as desirable overall characteristics for the network: a) It should cover the main types of soil found in the Valley of Mexico and several other places of special interest. b) It should be capable of simultaneously recording ground motion at sites hundreds of kilometers apart with an accurate, common time basis. c) Recording should be continuous and the whole system should, in general, operate through major earthquakes and commercial power failures lasting up to several days. d) Dynamic range should be comparable to that of conventional accelerographs. e) Records should be in a form suitable for efficient digitization. f) Provision should be made for future expansion of the original network.

To fulfill the above requirements a special telemetry system was devised, giving due consideration to the various factors involved. For instance, the transmission of sub-audio seismic signals with the least possible degradation indicated the use of FM techniques as appropriate. Because of the scarcity of telephone lines for continuous use in Mexico City, and total lack of them at some of the sites, it was necessary to consider radio links for signal transmission. Furthermore, each communication link is shared by several multiplexed FM signals which are recorded on one tape track. This approach has effected considerable savings in radio equipment, tape supplies and total number of recorder channels.

Since even major repairs and future additions should be undertaken by local personnel, the educational and training aspects of the project had to be considered in detail. The direct off-the-shelf purchase of certain components had to be compared to the more time-consuming task of designing, testing and producing them in the required quantities. Although this procedure would probably lead to higher initial costs, it would provide knowledge essential for proper maintenance.

After several layouts for the network were studied it appeared that a few seismometers feeding into standard drum recorders would be required as continuous monitors of seismic activity, providing visual indication of events possibly recorded on strong-motion channels, to ease the search of tapes. Incidentally, these stations would complement the seismological stations in the area and help in the determination of basic earthquake parameters.

### 3. DESCRIPTION OF THE NETWORK

#### 3.1 Location of field stations. The general layout of the field

stations as well as distances between them are shown schematically in fig. 1, together with the location of the central recording station (CRS) at the University campus. This figure includes a small array (marked SCOP) of three stations which is shown in detail in 1a.

The number of stations was limited mainly by total cost of the network. Their distribution was decided upon consideration of factors such as type of soil, accessibility, availability of commercial power supply and existence of line of sight between stations required for VHF radio transmission.

Two main types of field stations are used: those which sense translational acceleration along three orthogonal directions (TA) and those fitted with a short-period vertical seismometer (S). There are 12 of the first kind and four of the second combined as shown in fig. 1. In addition, there is a six-component station (three translational and three rotational accelerations) located in University grounds and hard-wired to CRS.

The longest radio link is 94 km, a distance satisfactorily bridged by 0.5-watt transmitters in quiet areas. In order to increase reliability, only one relay was allowed per line. The main triangle formed by the more distant seismometric stations has sides of the order of 150 km. This aperture and amplifications of about 50,000 as permitted by background noise allow reasonably good preliminary determination of seismic parameters for earthquakes of engineering interest at epicentral distances of up to 500 km from Mexico City, where most earthquakes to be sensed by strong motion stations will originate (1).

The distribution of TA stations within Mexico City, shown in fig. 1, is dictated by the relative importance of the three main types of soil and by density of construction, population and potential for future development. Two are located on relatively firm ground, one in the transition zone and six on lake-bed deposits. Of these, the Texcoco site consists of two stations: one on the surface and the other embedded in the thick clay layer some 20 m under the first. This arrangement will help verify results of theoretical studies on the effect of soft layers on earthquake accelerations.

The Puebla site is composed of two TA stations separated 30 m. Ground conditions are representative of the rather firm soil found in most of the city. These two stations and the three of the SCOP array are aimed at the determination of relative motion during earthquakes between points located at distances comparable to the dimensions of long structures.

### 3.2 Station characteristics

Sensors. Servo-accelerometers of the force-balance type were chosen as sensor units because of their cost, size, response characteristics, dynamic range, resolution, sensitivity, reliability and long-term

stability. In order to increase dynamic range wherever possible, low and high level signals are easily obtained from these accelerometers to cover approximate ranges of 1.0 to 0.02 g and 0.04 to 0.0008 g, respectively. Accelerometers with a natural frequency higher than 125 Hz, damping between 0.6 and 0.7 of critical and  $\pm 1.0$  g range were selected for this application.

The 1 g range calls for further comment. Although accelerations close to this value have very small probability of occurring in the network region within its probable useful life time (2), future extensions reaching as far south as the Pacific Coast increase considerably the probability of such an event. The convenience of uniform sensor characteristics was the overriding factor.

Following the recommendation of a UNESCO consultant, geophones are used as short period vertical seismometers. The type selected has natural frequency of 1 Hz and 5.5 Kohms coil resistance. Preamplifier input impedance is adjusted to obtain 0.7 of critical damping, thus securing a flat output for frequencies somewhat higher than 1.0 Hz. A low pass filter shapes the frequency response curve at the upper end.

Multiplexing system. After suitable conditioning (preamplification, filtering and standardization), accelerometer and seismometer outputs are multiplexed utilizing a number of subcarrier frequencies, obtained by means of integrated circuit type of voltage controlled oscillators (VCO). Outputs of these subcarrier generators are summed up linearly, thus obtaining a composite signal which frequency modulates the radio carrier itself. Systems of this type, known as FM/FM telemetry, are a well established practice in other areas than strong motion seismic sensing. In those applications, usually each information subchannel is capable of passing a gradually increasing bandwidth as the subcarrier frequency increases.

For seismic telemetering, however, all subchannels must be capable of the same bandwidth characteristics, as all transmitted signals are similar in frequency content, namely 0.05 to 25 Hz for acceleration and 0.5 to 10 Hz for the short period seismometers. A four pole input filter low-passes the accelerometer signals, thus restricting frequencies beyond 40 Hz that might interfere with the multiplexed signals. Also used is a high pass filter that rolls-off signals below 0.05 Hz at 6 dB per octave, to eliminate problems derived from possible accelerometer tilting.

Circuits in this system are so designed that full input voltage excursion produces a shift of  $\pm 125$  Hz from nine nominal frequencies. A feature of the circuitry protects each against interference from adjacent subcarriers in two ways, by limiting the voltage input and also by leaving a 90 Hz inter-channel guard band.

Lead-acid batteries floated from the commercial power line when

available are used. In isolated areas, primary cells with high ampere-hour rating such as air cells provide continuous operation without frequent replacement schedule.

Both transducers and circuitry are housed in waterproof steel containers fixed to concrete blocks and buried in the ground. A separate container is used for batteries or air cells. A condensed block diagram of a field station is shown in fig. 2a.

3.3 Radio links. Radio transmission is carried out in six channels allocated by the communication authorities. These are in the VHF band between 152 MHz and 174 MHz.

Narrow band frequency modulation is employed and both transmitter and receiver are crystal controlled and operate at a fixed frequency. The transmitter output power is 0.5 watts and the corresponding receivers sensitivity is  $0.5 \mu\text{V}$ . To achieve a good selectivity in a crowded VHF band the receiver makes use of two crystal filters which give a pass band of 20 KHz and a 90 dB rejection at both ends of a 25 KHz VHF channel. The audio response of the receiver is flat from 100 Hz to 4000 Hz in order to allow for the simultaneous transmission of ten seismic channels.

Multielement Yagi antennas, with an average gain of 9 dB are used throughout the system. Where local conditions are such that a better immunity from noise and interference is required two units are stacked, increasing both gain and directivity. Vertical and horizontal polarizations are used to obtain better channel separation.

The transmitter and the receiver make full use of integrated circuits which results in stable, economic operation and are water sealed and designed for continuous unattended operation. Consumption is no more than 140 mA and 40 mA respectively from a nominal 12 V supply.

Since the stations are often placed on exposed sites and the local weather is very stormy during certain months of the year, station towers are fitted with lightning rods and arc-gap arrestors are inserted in front of the equipment.

3.4 Central recording station. At the central recording station antennas and receivers are placed near the top of a 60 m tower. All other equipment is housed in an air-conditioned room of a nearby building. A basic block diagram is shown in fig. 2b.

Tape recording. A special magnetic tape recording system is included in this installation. It consists of three 14-channel one-inch tape transports selected for operation at 15/16 ips, with reels up to 14 in. The two transports which are used for recording are equipped with a shuttle device that automatically starts the idling machine when tape supply is short in the working one thus assuring continuous recording with some overlap. Total recording time is 36 and 54 hr, for 10.5 and

14 in. reels, respectively.

The third transport is used for tape reproducing. In its current configuration the system is fitted with eight direct recording channels in which the seven incoming multiplex signals are recorded, leaving one spare. Three FM channels are used for the WWVB time signal, for flutter compensation and one spare channel. In addition, a special direct recording channel is used for the timing code. Thus, the system is not saturated and contains three spare channels for future expansion.

Demodulator banks. The various multiplexed signals from the radio receiver or magnetic tape reproducer are processed in a demodulator bank. A group of pass band filters, tuned to the corresponding subcarrier frequency, separates each FM signal and feeds a phase locked loop (PLL) type of discriminator. This reconstitutes the signal as originally applied by the transducer at the field station. A pilot light emitting diode on the demodulating card continuously monitors the presence of the incoming subcarrier. Circuits are designed to include flutter compensation.

Timing. The heart of the timing system is a crystal controlled time code generator with a stability of 5 in  $10^6$  ppd. Synchronous time signals are fed into various recording media.

A time code reader allows a simple search to be done in the reproduced tape signals by translating the recorded time code at fast forward and rewind tape speeds. Also present are time marking pulses from this reader for use in display devices.

Radio received signals are used to set the generated code with WWVB time within 100  $\mu$ sec and as a spare in case of failure of the code generator.

Patch boarding. Conventional plug and cord methods of routing signals are cumbersome in a system of this complexity. To facilitate handling three pinboards are used accepting time, multiplex and analog signals, respectively. Both on-line and reproduced incoming signals are either hard-wire connected or otherwise protected against erroneous handling in the pinboards. All these signals can be diverted to demodulator banks, monitoring and processing system. Adjustable filters are available for shaping analog data prior to further digital processing. Additional input-output access to the pinboards is possible by means of external connectors.

Power supply. All equipment housed in the central recording station has a no-break system which assures uninterrupted operation. An electronic power inverter supplies 60 Hz to the equipment and is backed-up by a floated battery bank operated normally from the power line. An emergency plant takes over in the event of extended power interruptions.

Data Processing. Data handling is performed by a third generation mini-computer having 32K-16 bit memory. Peripheral equipment consists of:

disc-pack store, magnetic tape unit, D-A and A-D converters and a variety of input-output devices. The computer system is furnished with standard software. Large amounts of digitized data can be processed at the UNAM computing center.

#### 4. CONCLUSIONS

1. When fully operational, the network will provide continuous recording of ground accelerations throughout a sizable region during strong earthquake motion. A common time basis will permit precise correlation in time of motion at the various sites.

2. The high sensitivity recordings will frequently provide data on soil response for acceleration levels associated with behavior approaching linearity.

3. Modular construction, use of integrated circuits, continuous monitoring of subcarriers and systematic on-line use of a mini-computer for checking purposes will enhance dependability and facilitate adequate maintenance.

4. By the time debugging is near completion, detailed information about the various components of the network should be available. It could be duplicated elsewhere at a much lower cost.

#### 5. ACKNOWLEDGEMENTS

The network incorporates ideas expressed by many people at various times. Special mention should be made of E. Rosenblueth, L. Esteva, E. Faccioli, I. Kiralyfalvi, W. Jackson, P. L. Willmore, S. Crampin and N. N. Ambraseys. The enthusiastic work of J. M. Espinosa, J. García L., G. Legaria, G. López V., E. Mena, R. Peters and R. Quass has been an invaluable contribution. The active participation of T.V. Mc Evilly in the early stages of the project is also gratefully acknowledged.

#### REFERENCES

1. Lomnitz, C., personal communication
2. Esteva, L., Regionalización sísmica de México para fines de ingeniería, Institute of Engineering Publication 246, April 1970.

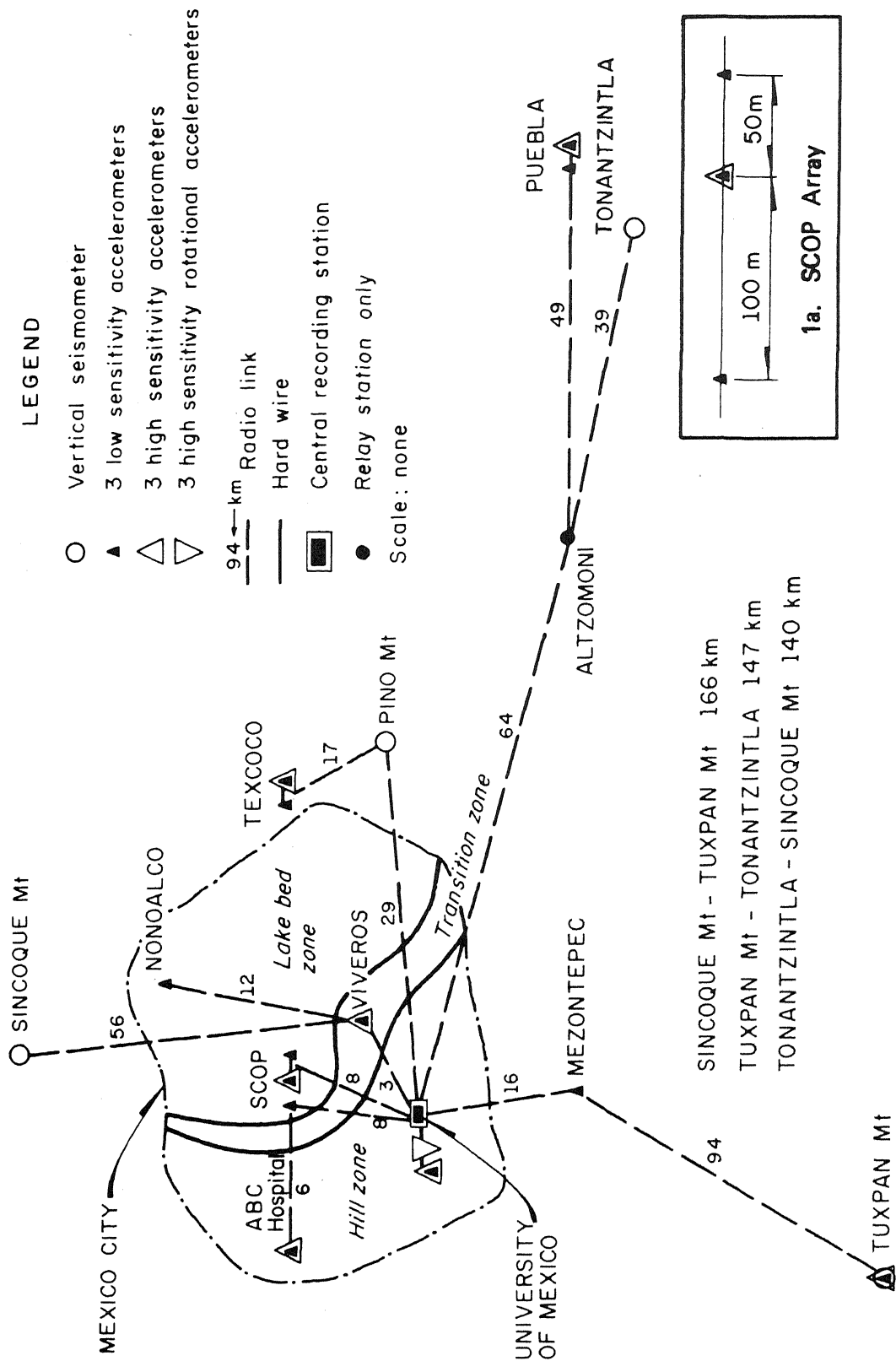

FIG 1. LAYOUT OF SEISMIC TELEMETRY NETWORK (SCHEMATIC)

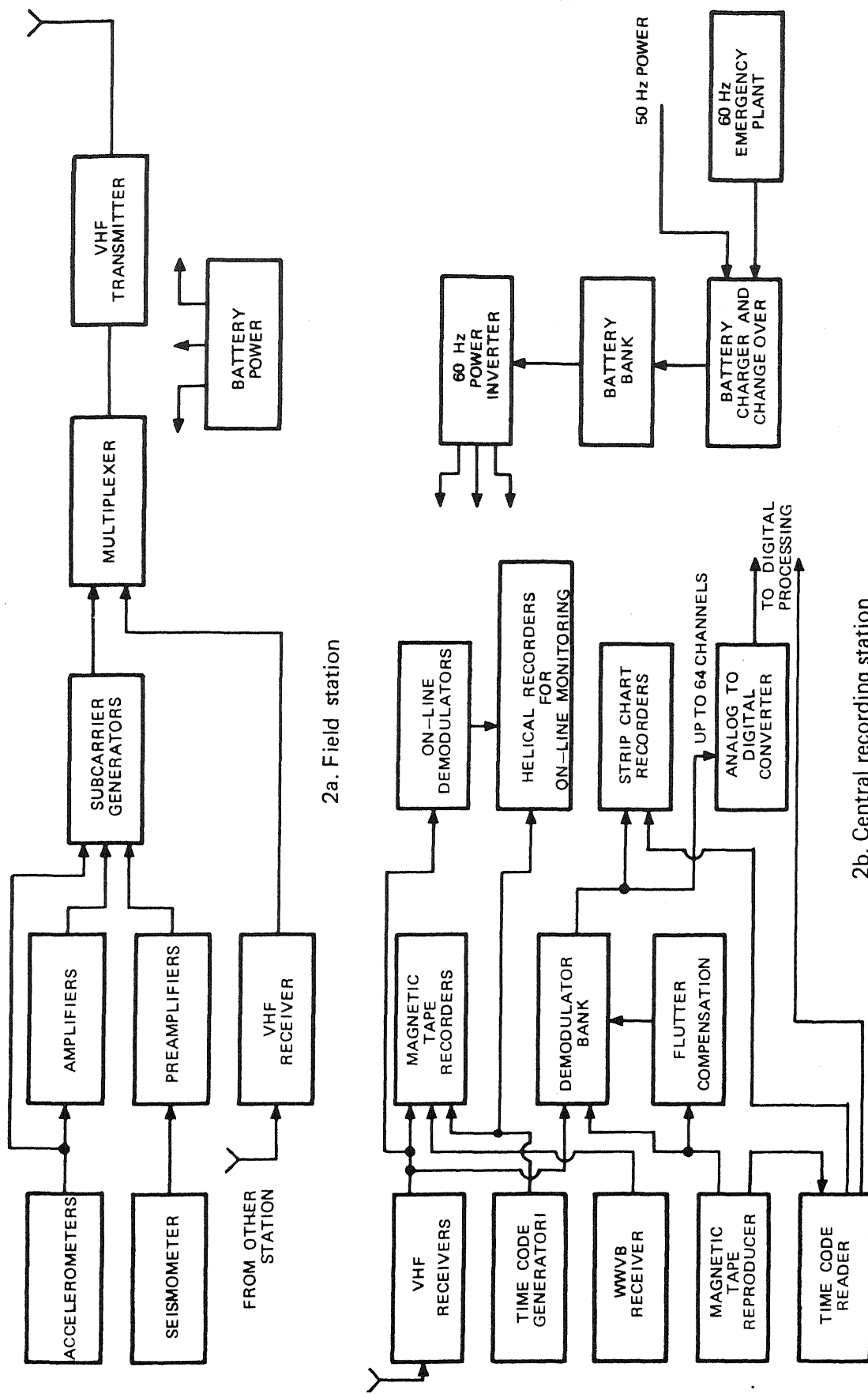

FIG 2. BASIC BLOCK DIAGRAMS OF FIELD AND CENTRAL RECORDING STATIONS